



LAGUNA 25
SISTEMA DE ESQUADRIAS

ÍNDICE GERAL

	Página
A NOSSA HISTÓRIA	03
A EMPRESA	04
INFORMAÇÕES TÉCNICAS SISTEMA DE ESQUADRIAS LAGUNA 25	05
GRÁFICOS DE DIMENSÕES	08
TIPOLOGIAS	17
ÍNDICE DE PERFIS	19
PERFIS SISTEMA DE ESQUADRIAS LAGUNA 25	20
ÍNDICE DE COMPONENTES	53
COMPONENTES	54
ÍNDICE DE USINAGENS	77
USINAGENS	78
ÍNDICE DE DETALHES CONSTRUTIVOS	89
DETALHES CONSTRUTIVOS	90

NOSSA HISTÓRIA

Foi em 1895, que a família Fretta ingressou na atividade comercial, ao fundar na localidade de Azambuja - SC a Casas Fretta. Mais de 120 anos se passaram desde então, e sua tradição ultrapassou gerações, tornando a empresa uma das mais antigas do estado de Santa Catarina, sob o comando dos descendentes de seus fundadores.

EXPERIÊNCIA E CONSTANTE EVOLUÇÃO

Tanto tempo de experiência conferiu ao grupo Fretta um legado de credibilidade, resultando na consolidação da marca, sinônimo de solidez e excelência na prestação de serviços.

A tradição nos negócios, aprimorada com o tempo, deu vazão a novos empreendimentos.

O grupo Fretta diversificou seu ramo de atuação e hoje, além da Casas Fretta, é composto pela Fretta Construções, Invest Capital e a mais recente integrante do grupo: Aludim Aluminum Technology.

Especializada na extrusão de alumínio para a construção civil e para a atividade industrial, a Aludim traz em seu DNA os mesmos valores do grupo Fretta, compartilhando da paixão pela prestação de serviços com alto padrão de qualidade.

O Grupo Fretta cresceu e está cada vez mais presente na vida das pessoas, conservando os ensinamentos de seus fundadores: ajudar a transformar o mundo, investindo no ser humano e trabalhando para fazer sua vida melhor!



Azambuja, 1895. Primeira casa de comércio da família Fretta.



ALUMÍNIO PRESENTE EM CADA DETALHE DA VIDA MODERNA

Beleza, leveza, durabilidade, moldabilidade, alta resistência, inclusive à corrosão, são algumas das qualidades que tornam o alumínio essencial à vida moderna. Considerado metal semiprecioso, no século XIX o alumínio chegou a ser mais caro do que o ouro, no entanto, a produção em larga escala tornou o preço acessível, ampliando sua utilização.

AQUI, O ALUMÍNIO É BEM TRATADO

A Aludim mantém parcerias com os mais modernos e equipados complexos industriais de tratamento de superfície de perfis extrudados de alumínio, empresas que dispõem de uma linha completa de pintura e de anodização. Tudo isso confere aos produtos Aludim alta resistência, qualidade estética, diversidade de cores, texturas e acabamentos, atributos que se adaptam às necessidades e aos padrões de seu projeto, agregando valor ao seu produto.

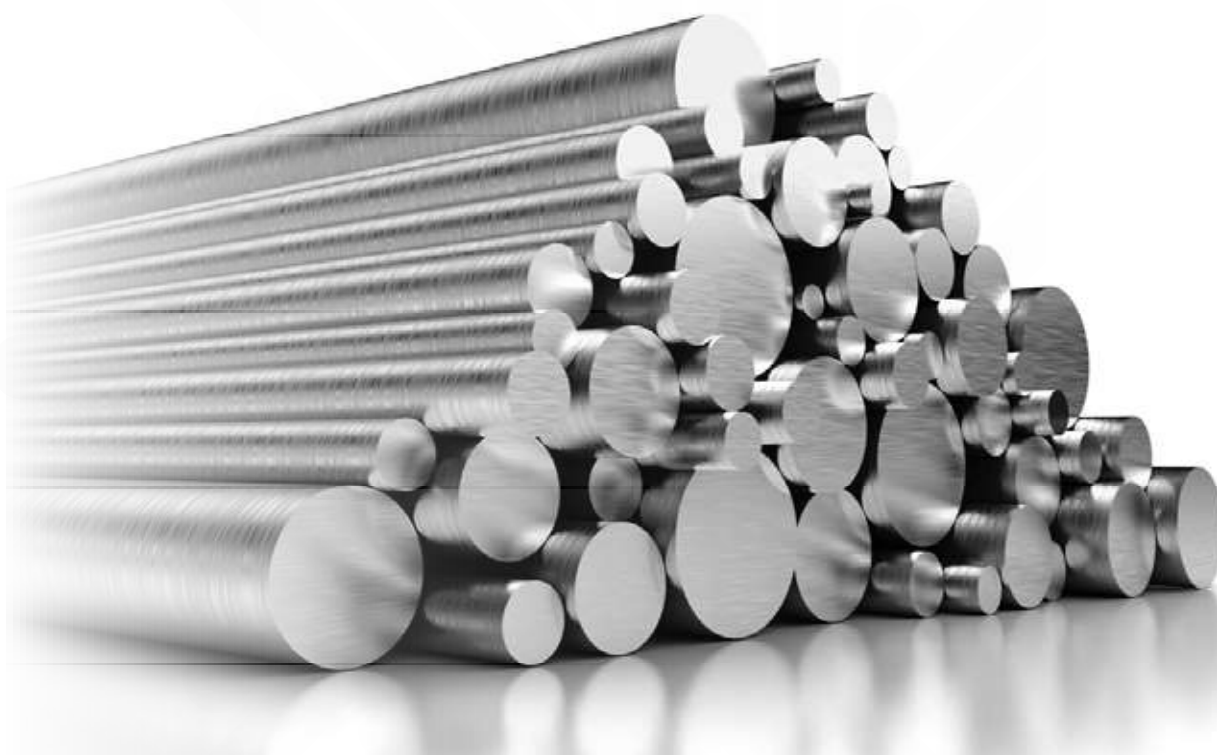

SUSTENTABILIDADE

Atualmente, o alumínio está presente em diversos segmentos, contribuindo, inclusive para a preservação do meio ambiente, pois, além de ser o metal ideal para o desenvolvimento de produtos que permitem a redução da emissão de gases poluentes, cerca de 75% de todo o alumínio produzido, até hoje, ainda está em uso. Como um material infinitamente reciclável, mesmo depois de décadas de vida útil, o alumínio pode ser reaproveitado, gerando grande economia de recursos financeiros e preservação dos recursos naturais.

RESPONSABILIDADE SOCIAL

A Aludim escreve diariamente uma história de inovação e compromisso com a sustentabilidade. A preocupação com aspectos econômicos, sociais e ambientais faz parte dos valores da empresa, por isso a companhia busca, constantemente, o aumento de sua eficiência operacional, para diminuir os desperdícios do processo produtivo. Para tanto, desenvolve projetos de conservação de recursos e ecoeficiência, focados na redução de emissões atmosféricas, geração de resíduos sólidos industriais e do consumo de água.

A Associação Brasileira de Normas Técnicas (ABNT) é o Foro Nacional de Normalização. As Normas Brasileiras, cujo conteúdo é de responsabilidade dos Comitês Brasileiros (ABNT/CB), dos Organismos de Normalização Setorial (ABNT/ONS) e das Comissões de Estudos Especiais (ABNT/CEE), são elaboradas por Comissões de Estudo (CE), formadas pelas partes interessadas no tema objetivo da normalização.

Referências Normativas:

- ABNT - NBR 15.575 - Desempenho - Edifícios habitacionais
- ABNT - NBR 10.821 - Esquadrias externas para edificações
- ABNT - NBR 6.123 - Forças devidas ao vento em edificações - Procedimento
- ABNT - NBR 7.199 - Projeto, execução e aplicação dos vidros na construção civil
- ABNT - NBR 7.000 - Alumínio e suas ligas - Produtos extrudados - Propriedades mecânicas
- ABNT - NBR 8.116 - Alumínio e suas ligas - Produtos extrudados - Tolerâncias dimensionais
- ABNT - NBR 15.969 - Componentes para esquadrias

ABNT NBR 7.000 - Alumínio e suas ligas

Esta Norma especifica as propriedades mecânicas dos perfis de alumínio e suas ligas, determinados nesse catálogo.

Tabela de propriedades físicas e mecânicas das ligas recomendadas.

Liga - Têmpera	Peso Específico (Kg/m)	Módulo Young (Elasticidade) (Mpa)	Temperatura De Fusão (°C)	Coefficiente De Expansão Linear (L/°C)	(LRT) Limite De Resistência a Tração (Mpa)	Limite Convencional De Escoamento (Mpa)
6060 - T5	2,71	70.000	600 - 650	23x10 ⁻⁶	150 (219)	110 (189)
6063 - T5	2,71	70.000	600 - 650	23x10 ⁻⁶	150 (219)	110 (189)
6063 - T6	2,71	70.000	600 - 650	24x10 ⁻⁶	205 (235)	170 (213)

Observações:

Dados de tensão expressos na unidade MEGAPASCAL (Mpa), equivale a 1 N/mm².

A medida da unidade Kgf/mm² é obtida dividindo-se o valor indicado por 9,807.

Os valores sem parênteses são os mínimos especificados e valores entre parênteses são os típicos esperados e referem-se aos produtos mais utilizados nas ligas/têmperas indicadas.

As características e as propriedades mecânicas das têmperas com alívio de tensão podem diferir daquelas correspondentes as têmperas básicas do produto.

Norma ABNT NBR 10.821

A norma ABNT NBR 10.821 estabelece os parâmetros mínimos de desempenho exigidos de esquadrias para instalações em edifícios.

Ela trata dos seguintes requisitos para aplicações externas:

- Permeabilidade ao ar;
- Estanqueidade à água;
- Resistência as cargas uniformemente distribuídas;
- Resistência as operações de manuseio;

O atendimento das exigências estabelecidas pela norma é verificado através de ensaios específicos realizados em laboratórios especializados.

As exigências variam de acordo com a localização e algumas outras características da obra, como altura, a topografia, entre outras.

Figura 1 - Gráfico de isopletas de velocidade básica dos ventos no Brasil - ABNT 6123

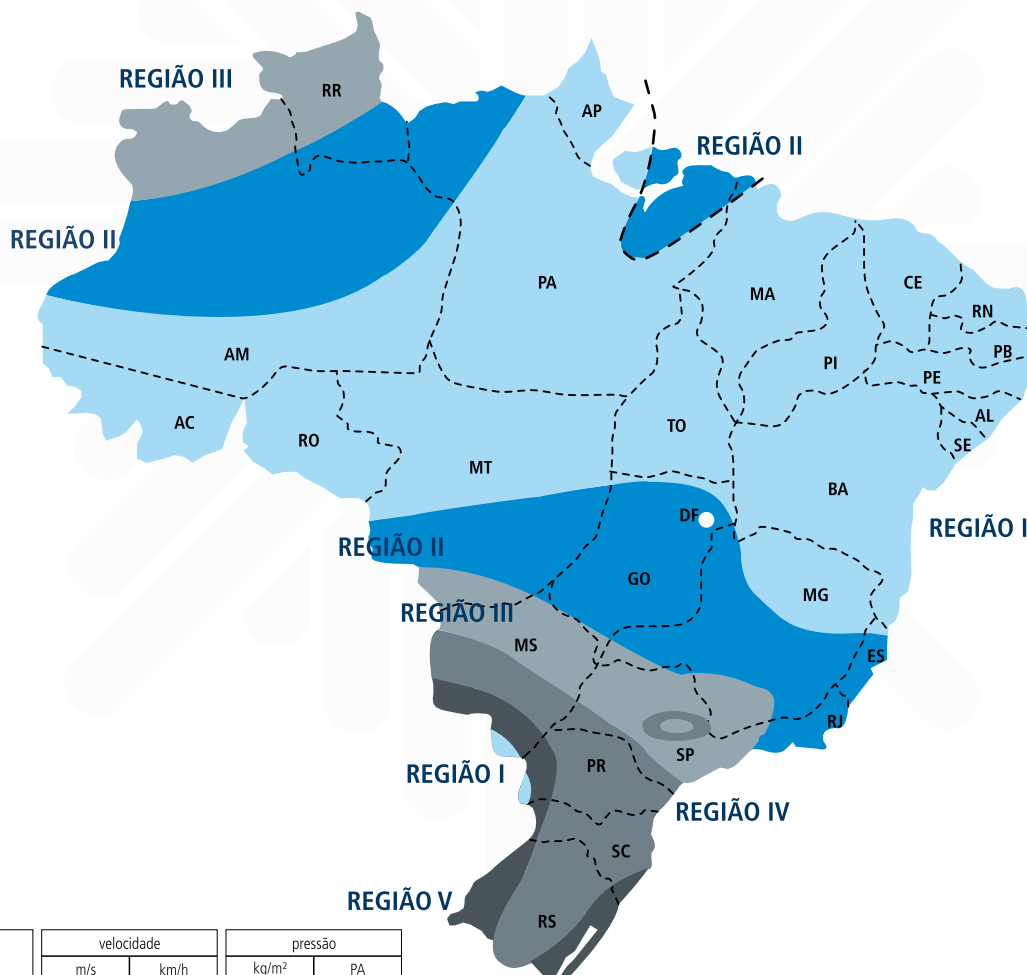

Região	velocidade		pressão	
	m/s	km/h	kg/m ²	PA
I	30	108	77	756
II	35	126	105	1030
III	40	144	137	1345
IV	45	162	173	1698
V	50	180	214	2100

A velocidade do vento é o parâmetro inicial para calcularmos a pressão exercida o local, levando em conta a altura da obra, rugosidade do terreno, localização, entre outras características. Para facilitar a NBR 10821 trás uma tabela (tabela 1), que determina as pressões de ensaio, segurança e de água, válida para edifícios de até 30 pavimentos ou 90 metros de altura em todas as regiões do Brasil.

Os requisitos de classificação das esquadrias instaladas na posição vertical, em edifícios de uso residencial ou comercial, são no mínimo estabelecidos para as cinco classes em relação ao número de pavimentos e a altura da edificação. As pressões de ensaios a serem adotadas estão indicadas na Tabela 1 e na Figura 1, sendo sempre considerado o último pavimento da edificação onde as esquadrias forem ser instaladas, mantendo-se este valor para todos os pavimentos.

Para esquadrias instaladas nas situações a seguir, deve ser consultada a ABNT NBR 6123, para determinação da pressão de projeto (P_p) e pressão de ensaio (P_e), prevalecendo como o mínimo os valores da Tabela 1 .

- Edifícios em que as esquadrias não sejam instaladas na posição vertical;
- Edifícios de forma não retangular;
- Edifícios com exigências especiais;

Tabela 1 - Tabela de pressão de ensaio para cargas uniformemente distribuídas

Tabela de pressão de ensaio para cargas uniformemente distribuídas					
Quantidade de pavimentos	Altura máxima	Região do País	Pressão de ensaio P_e , em (Pa) Positiva e negativa $P_e = P_p \times 1,2$	Pressão de segurança P_s , em (Pa) Positiva e negativa $P_s = P_e \times 1,5$	Pressão de água P_a , em (Pa) $P_a = P_p \times 0,20$
02	6 m	I	350	520	60
		II	470	700	80
		III	610	920	100
		IV	770	1160	130
		V	950	1430	160
05	15 m	I	420	640	70
		II	580	860	100
		III	750	1130	130
		IV	950	1430	160
		V	1180	1760	200
10	30 m	I	500	750	80
		II	680	1030	110
		III	890	1340	150
		IV	1130	1700	190
		V	1400	2090	230
20	60 m	I	600	900	100
		II	815	1220	140
		III	1060	1600	180
		IV	1350	2020	220
		V	1660	2500	280
30	90 m	I	660	980	110
		II	890	1340	150
		III	1170	1750	200
		IV	1480	2210	250
		V	1820	2730	300

Com as pressões definidas, é possível verificar nas páginas dos 'Gráficos de Desempenho', as medidas máximas de largura e altura para as tipologias existentes em sua edificação. Para isso ligue o eixo de largura ou de altura na curva referente a pressão de ensaio encontrada e verifique a dimensão máxima correspondente.

Notas:

- Nos gráficos de desempenho a seguir, foram considerados os valores de 'Pressão de Ensaio' e ' Pressão de Segurança' de acordo com a norma ABNT NBR 10.821.
- As espessuras dos vidros devem ser calculadas utilizando-se o valor da 'Pressão de Segurança' requerida para a esquadria (para maiores informações consultar a ABNT NBR 10.821 - partes 2 e 3).

Janela de Correr 2, 3 e 4 Folhas

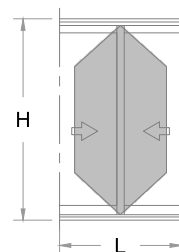
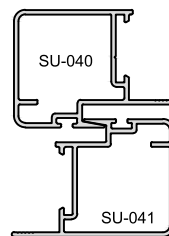
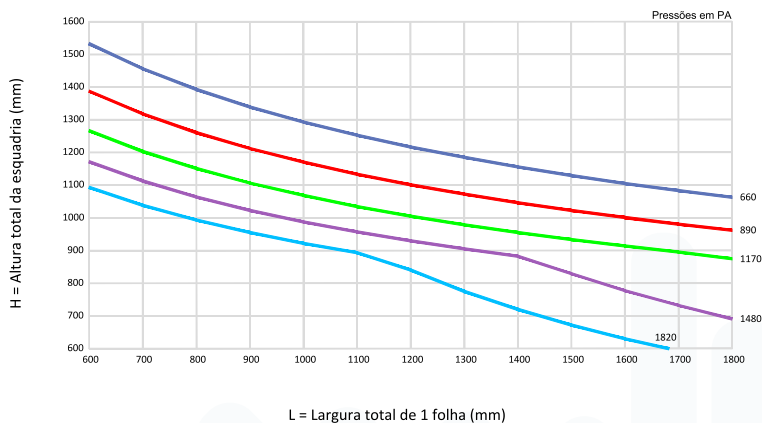

DADOS GEOMÉTRICOS	
SU-040	SU-041
Jx: 2,2470 Cm ⁴	Jx: 2,4841 Cm ⁴
Wx: 1,3408 Cm ³	Wx: 1,5279 Cm ³
Jxt: 4,7311 Cm ⁴	Jxt: 4,7311 Cm ⁴
Wxt: 2,8687 Cm ³	Wxt: 2,8687 Cm ³

Tensão Admissível: 7 Kg/mm² (Liga 6060-T5)
 Flecha Admissível: H / 175 ou 30mm

Janela de Correr 2, 3 e 4 Folhas

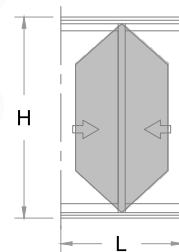
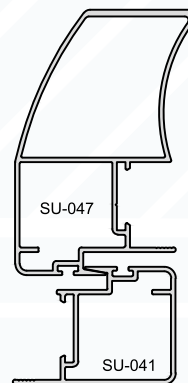
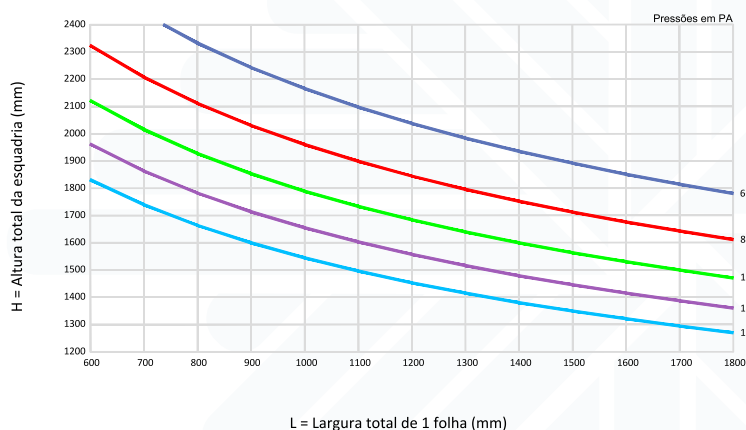

DADOS GEOMÉTRICOS	
SU-047	SU-041
Jx: 19,7579 Cm ⁴	Jx: 2,4841 Cm ⁴
Wx: 5,4204 Cm ³	Wx: 1,5279 Cm ³
Jxt: 22,2420 Cm ⁴	Jxt: 22,2420 Cm ⁴
Wxt: 6,9483 Cm ³	Wxt: 6,9483 Cm ³

Tensão Admissível: 7 Kg/mm² (Liga 6060-T5)
 Flecha Admissível: H / 175 ou 30mm

Janela de Correr 2, 3 e 4 Folhas

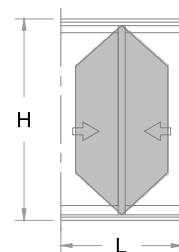
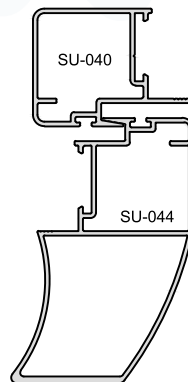
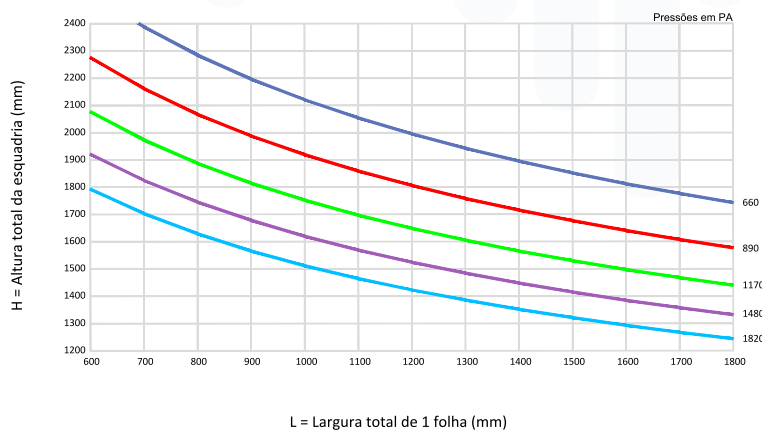

DADOS GEOMÉTRICOS	
SU-040	SU-044
Jx: 2,2470 Cm ⁴	Jx: 18,6370 Cm ⁴
Wx: 1,3408 Cm ³	Wx: 5,2834 Cm ³
Jxt: 4,7311 Cm ⁴	Jxt: 20,8840 Cm ⁴
Wxt: 2,8687 Cm ³	Wxt: 6,6242 Cm ³

Tensão Admissível: 7 Kg/mm² (Liga 6060-T5)
 Flecha Admissível: H / 175 ou 30mm

Porta de Correr 2,3 e 4 Folhas

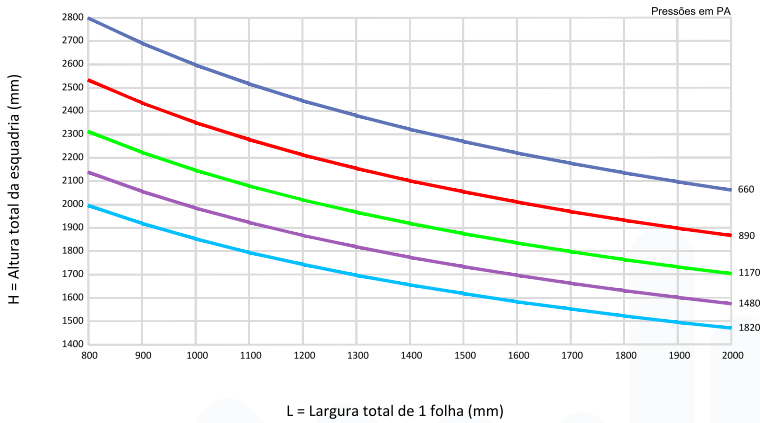

Tensão Admissível: 7 Kg/mm² (Liga 6060-T5)
 Flecha Admissível: H / 175 ou 30mm

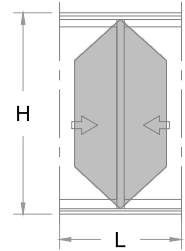
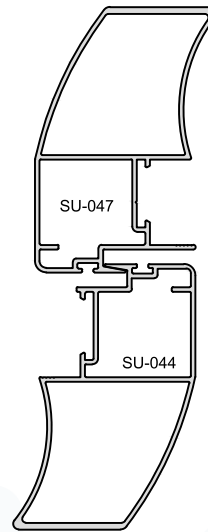

DADOS GEOMÉTRICOS	
SU-047	SU-044
Jx: 19,7579 Cm ⁴	Jx: 18,6370 Cm ⁴
Wx: 5,4204 Cm ³	Wx: 5,2834 Cm ³
Jxt: 38,3949 Cm ⁴	Jxt: 38,3949 Cm ⁴
Wxt: 10,7038 Cm ³	Wxt: 10,7038 Cm ³

Janela de Correr 3 e 6 Folhas

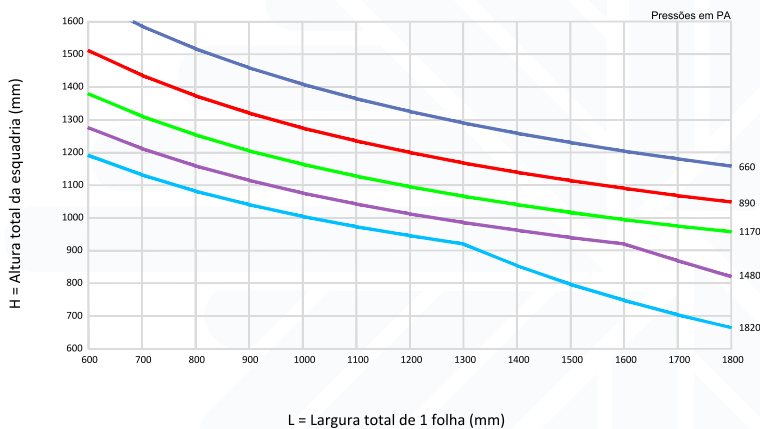

Tensão Admissível: 7 Kg/mm² (Liga 6060-T5)
 Flecha Admissível: H / 175 ou 30mm

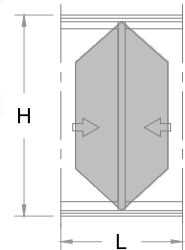
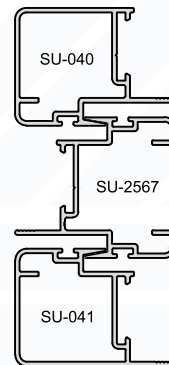

DADOS GEOMÉTRICOS	
SU-2567	SU-041
Jx: 3,6376 Cm ⁴	Jx: 2,4841 Cm ⁴
Wx: 1,8773 Cm ³	Wx: 1,5279 Cm ³
Jxt: 6,1217 Cm ⁴	Jxt: 6,1217 Cm ⁴
Wxt: 3,4052 Cm ³	Wxt: 3,4052 Cm ³

Porta de Correr 3 e 6 Folhas

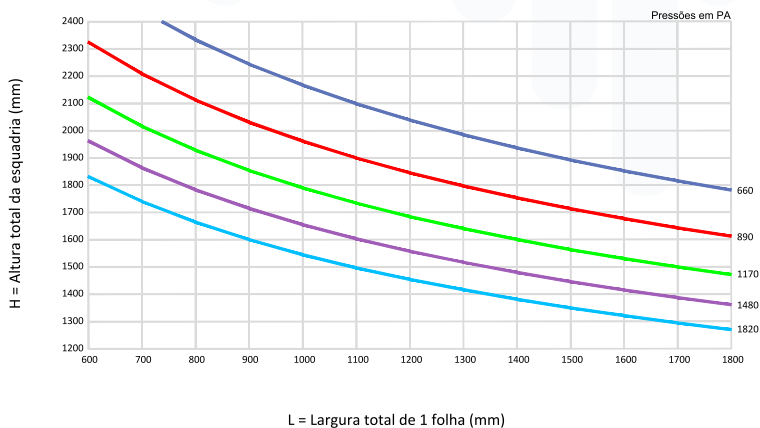

Tensão Admissível: 7 Kg/mm² (Liga 6060-T5)
 Flecha Admissível: H / 175 ou 30mm

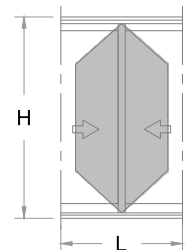
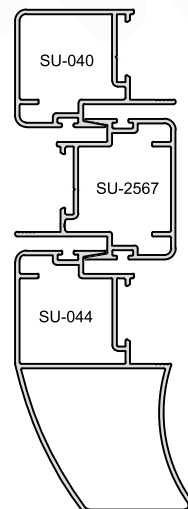

DADOS GEOMÉTRICOS	
SU-2567	SU-044
Jx: 3,6376 Cm ⁴	Jx: 18,6370 Cm ⁴
Wx: 1,8773 Cm ³	Wx: 5,2834 Cm ³
Jxt: 22,2746 Cm ⁴	Jxt: 22,2746 Cm ⁴
Wxt: 7,1607 Cm ³	Wxt: 7,1607 Cm ³

Janela de Correr 4,6 e 8 Folhas

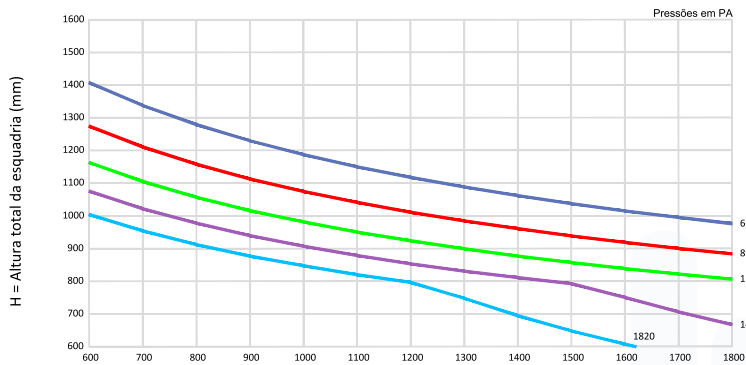

L = Largura total de 1 folha (mm)

Tensão Admissível: 7 Kg/mm² (Liga 6060-T5)
 Flecha Admissível: H / 175 ou 30mm

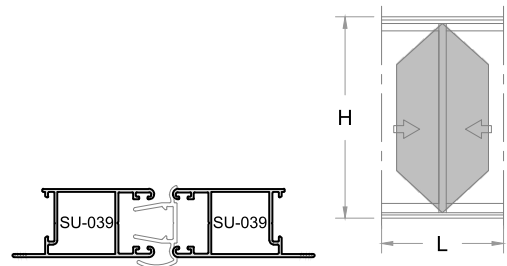

DADOS GEOMÉTRICOS	
SU-039	SU-039
Jx: 1,8325 Cm ⁴	Jx: 1,8325 Cm ⁴
Wx: 1,3837 Cm ³	Wx: 1,3837 Cm ³
Jxt: 3,6650 Cm ⁴	Jxt: 3,6650 Cm ⁴
Wxt: 2,7674 Cm ³	Wxt: 2,7674 Cm ³

Janela de Correr 4, 6 e 8 Folhas

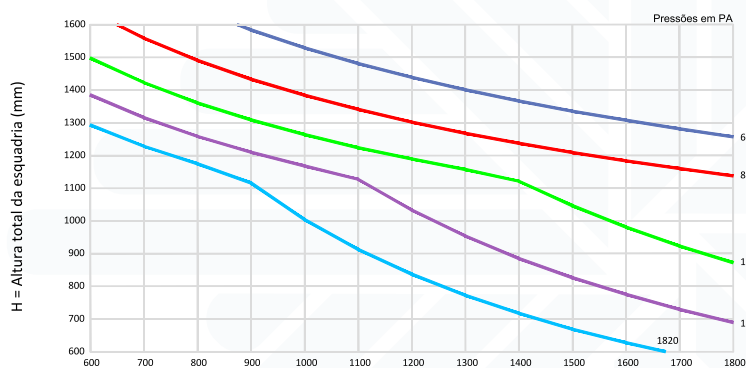

L = Largura total de 1 folha (mm)

Tensão Admissível: 7 Kg/mm² (Liga 6060-T5)
 Flecha Admissível: H / 175 ou 30mm

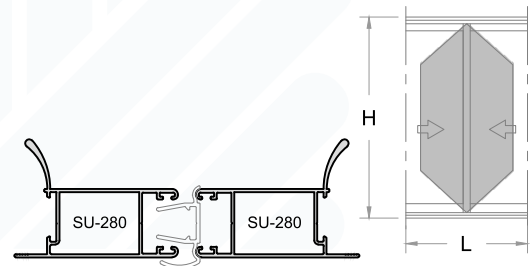

DADOS GEOMÉTRICOS	
SU-280	SU-280
Jx: 3,9153 Cm ⁴	Jx: 3,9153 Cm ⁴
Wx: 1,4291 Cm ³	Wx: 1,4291 Cm ³
Jxt: 7,8306 Cm ⁴	Jxt: 7,8306 Cm ⁴
Wxt: 2,8582 Cm ³	Wxt: 2,8582 Cm ³

Janela de Correr 4, 6 e 8 Folhas



L = Largura total de 1 folha (mm)

Tensão Admissível: 7 Kg/mm² (Liga 6060-T5)
 Flecha Admissível: H / 175 ou 30mm

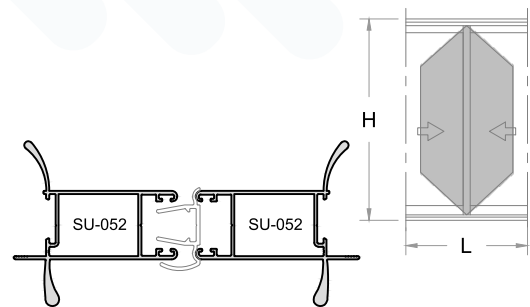

DADOS GEOMÉTRICOS	
SU-052	SU-052
Jx: 6,7117 Cm ⁴	Jx: 6,7117 Cm ⁴
Wx: 2,0974 Cm ³	Wx: 2,0974 Cm ³
Jxt: 13,4234 Cm ⁴	Jxt: 13,4234 Cm ⁴
Wxt: 4,1948 Cm ³	Wxt: 4,1948 Cm ³

Porta de Correr 4,6 e 8 Folhas

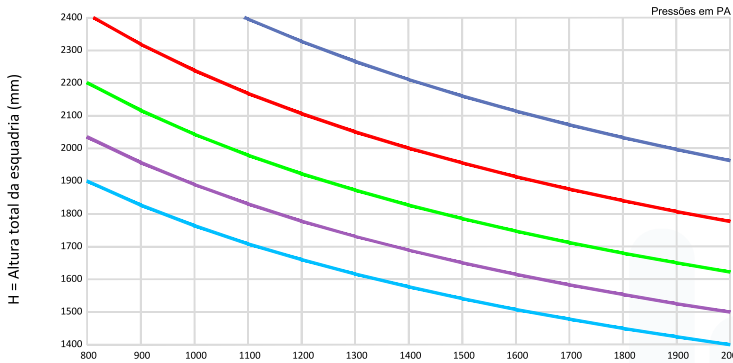

L = Largura total de 1 folha (mm)

Tensão Admissível: 7 Kg/mm² (Liga 6060-T5)
Flecha Admissível: H / 175 ou 30mm

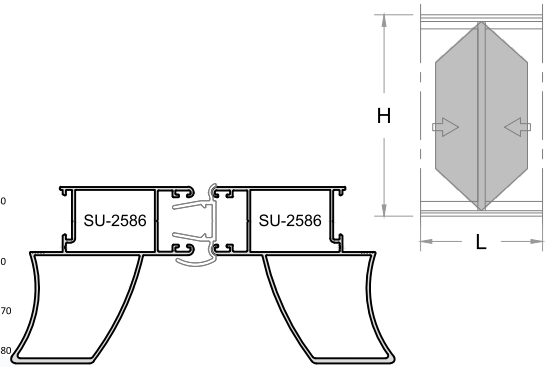

DADOS GEOMÉTRICOS	
SU-2586	SU-2586
Jx: 16,5637 Cm ⁴	Jx: 16,5637 Cm ⁴
Wx: 4,8440 Cm ³	Wx: 4,8440 Cm ³
Jxt: 33,1274 Cm ⁴	
Wxt: 9,6880 Cm ³	

Janela de Correr 2, 3 e 4 Folhas

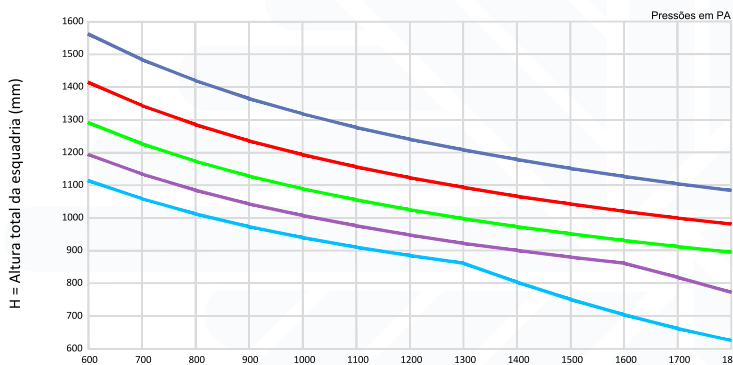

L = Largura total de 1 folha (mm)

Tensão Admissível: 7 Kg/mm² (Liga 6060-T5)
Flecha Admissível: H / 175 ou 30mm

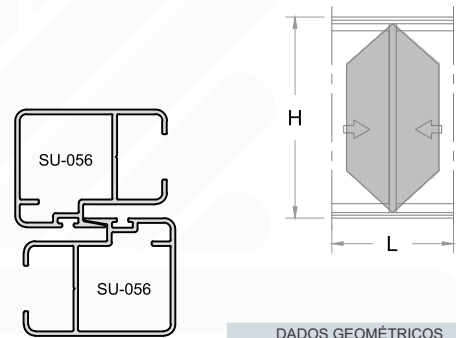

DADOS GEOMÉTRICOS	
SU-056	SU-056
Jx: 2,5073 Cm ⁴	Jx: 2,5073 Cm ⁴
Wx: 1,6028 Cm ³	Wx: 1,6028 Cm ³
Jxt: 5,0146 Cm ⁴	
Wxt: 3,2056 Cm ³	

Janela de Correr 2, 3 e 4 Folhas

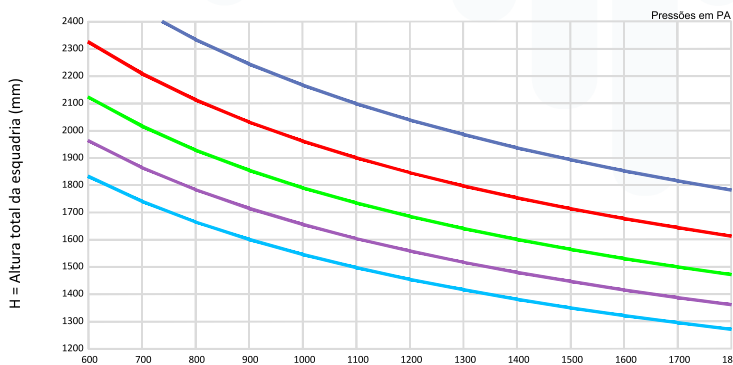

L = Largura total de 1 folha (mm)

Tensão Admissível: 7 Kg/mm² (Liga 6060-T5)
Flecha Admissível: H / 175 ou 30mm

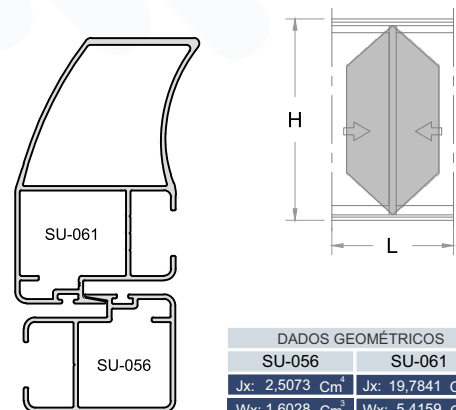

DADOS GEOMÉTRICOS	
SU-056	SU-061
Jx: 2,5073 Cm ⁴	Jx: 19,7841 Cm ⁴
Wx: 1,6028 Cm ³	Wx: 5,4159 Cm ³
Jxt: 22,2914 Cm ⁴	
Wxt: 7,0187 Cm ³	

Porta de Correr 4, 6 e 8 Folhas

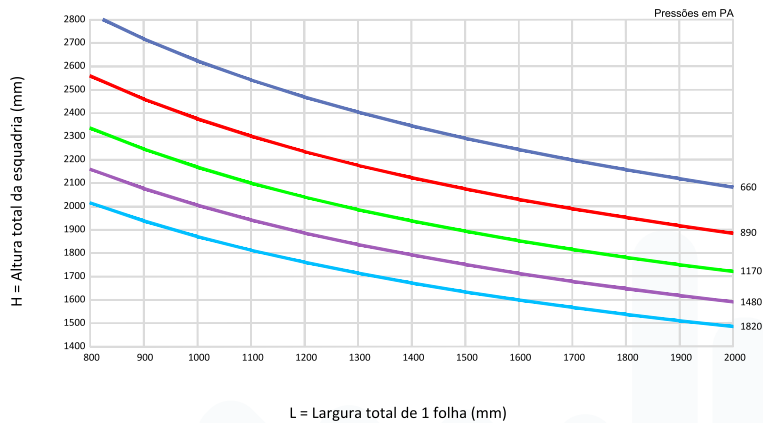

Tensão Admissível: 7 Kg/mm² (Liga 6060-T5)
 Flecha Admissível: H / 175 ou 30mm

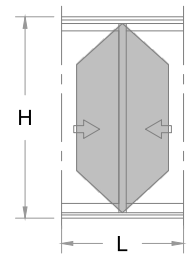
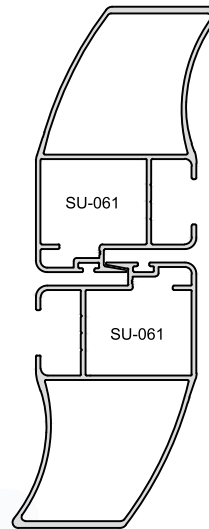

DADOS GEOMÉTRICOS	
SU-061	SU-061
Jx: 19,7841 Cm ⁴	Jx: 19,7841 Cm ⁴
Wx: 5,4159 Cm ³	Wx: 5,4159 Cm ³
Jxt: 39,5682 Cm ⁴	Jxt: 39,5682 Cm ⁴
Wxt: 10,8318 Cm ³	Wxt: 10,8318 Cm ³

Janela de Correr 3 e 6 Folhas

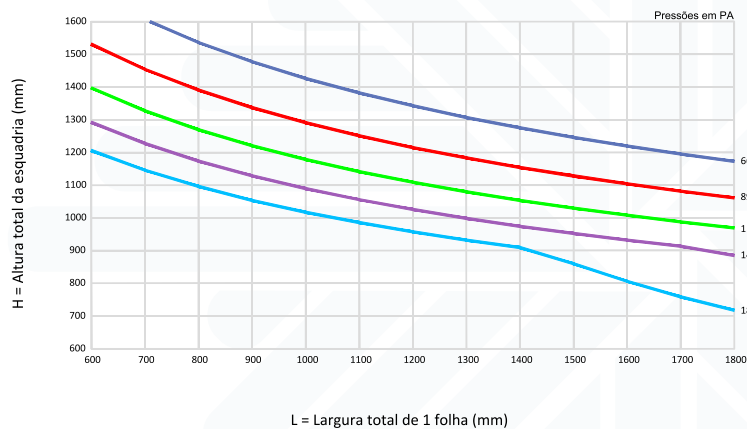

Tensão Admissível: 7 Kg/mm² (Liga 6060-T5)
 Flecha Admissível: H / 175 ou 30mm

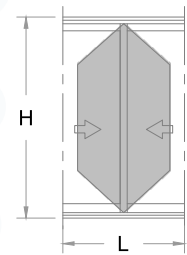
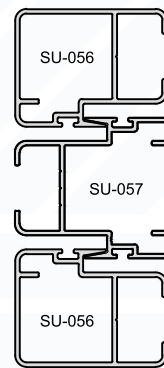

DADOS GEOMÉTRICOS	
SU-057	SU-056
Jx: 3,8523 Cm ⁴	Jx: 2,5073 Cm ⁴
Wx: 2,0698 Cm ³	Wx: 1,6028 Cm ³
Jxt: 6,3596 Cm ⁴	Jxt: 6,3596 Cm ⁴
Wxt: 3,6726 Cm ³	Wxt: 3,6726 Cm ³

Porta de Correr 3 e 6 Folhas

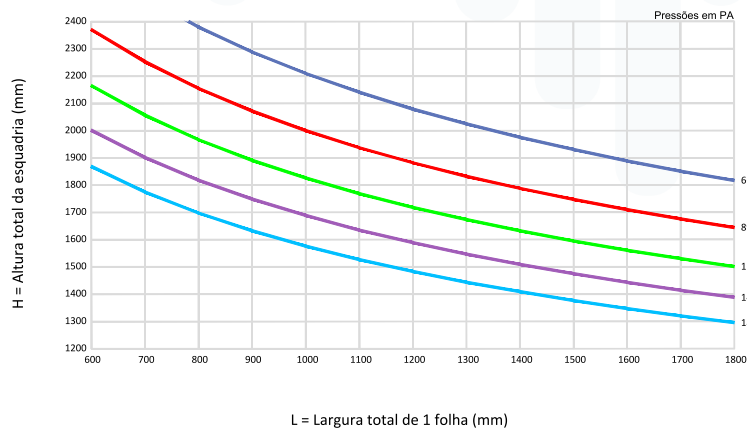

Tensão Admissível: 7 Kg/mm² (Liga 6060-T5)
 Flecha Admissível: H / 175 ou 30mm

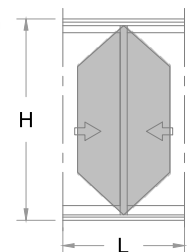
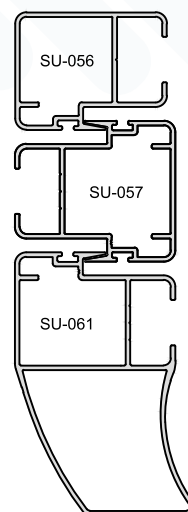

DADOS GEOMÉTRICOS	
SU-057	SU-061
Jx: 3,8523 Cm ⁴	Jx: 19,7841 Cm ⁴
Wx: 2,0698 Cm ³	Wx: 5,4159 Cm ³
Jxt: 23,6364 Cm ⁴	Jxt: 23,6364 Cm ⁴
Wxt: 7,4857 Cm ³	Wxt: 7,4857 Cm ³

Janela de Correr 4, 6 e 8 Folhas

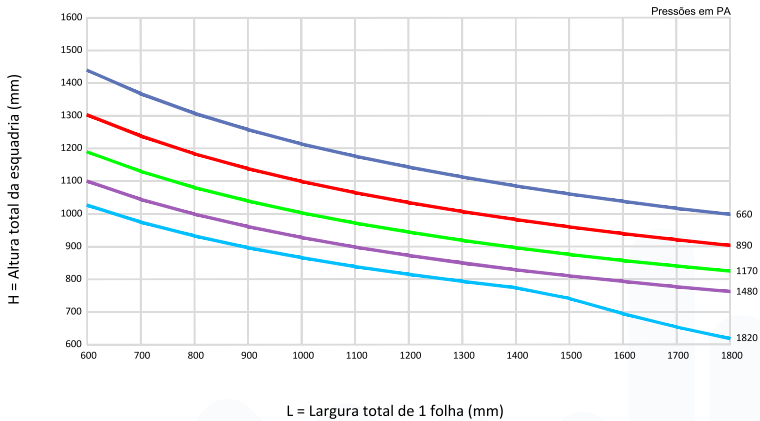

Tensão Admissível: 7 Kg/mm² (Liga 6060-T5)
 Flecha Admissível: H / 175 ou 30mm

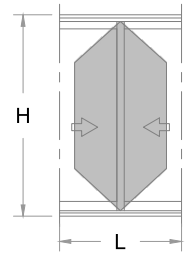
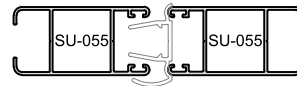

DADOS GEOMÉTRICOS	
SU-055	SU-055
Jx: 1,9588 Cm ⁴	Jx: 1,9588 Cm ⁴
Wx: 1,5829 Cm ³	Wx: 1,5829 Cm ³
Jxt: 3,9176 Cm ⁴	Jxt: 3,9176 Cm ⁴
Wxt: 3,1658 Cm ³	Wxt: 3,1658 Cm ³

Janela de Correr 4,6 e 8 Folhas

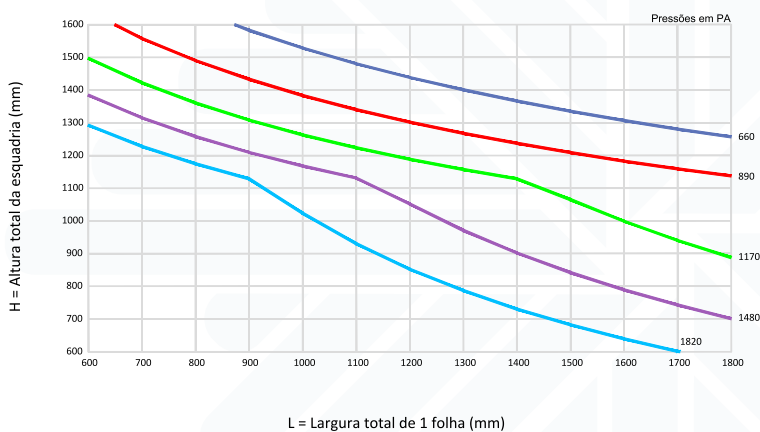

Tensão Admissível: 7 Kg/mm² (Liga 6060-T5)
 Flecha Admissível: H / 175 ou 30mm

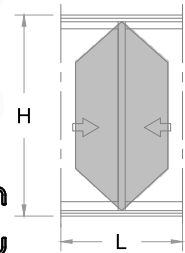
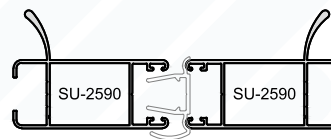

DADOS GEOMÉTRICOS	
SU-2590	SU-2590
Jx: 3,9110 Cm ⁴	Jx: 3,9110 Cm ⁴
Wx: 1,4570 Cm ³	Wx: 1,4570 Cm ³
Jxt: 7,8220 Cm ⁴	Jxt: 7,8220 Cm ⁴
Wxt: 2,9140 Cm ³	Wxt: 2,9140 Cm ³

Porta de Correr 4,6 e 8 Folhas

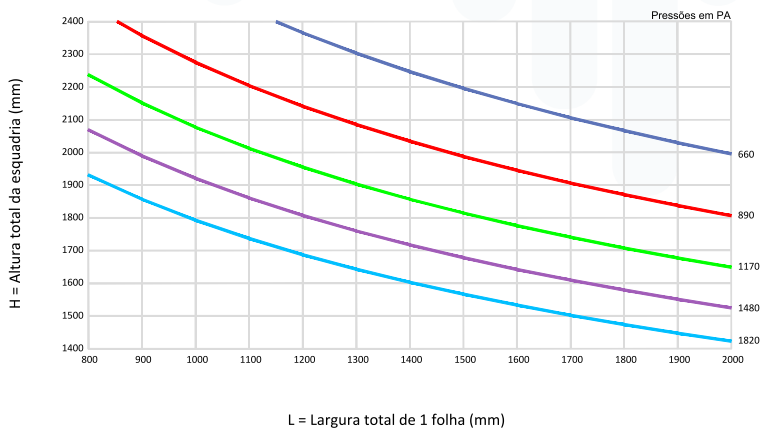

Tensão Admissível: 7 Kg/mm² (Liga 6060-T5)
 Flecha Admissível: H / 175 ou 30mm

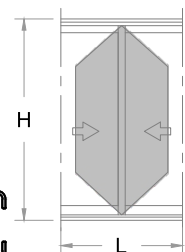
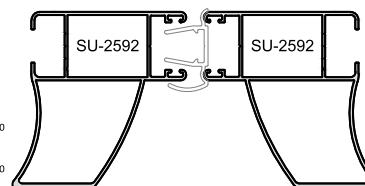

DADOS GEOMÉTRICOS	
SU-2592	SU-2592
Jx: 17,4037 Cm ⁴	Jx: 17,4037 Cm ⁴
Wx: 4,9665 Cm ³	Wx: 4,9665 Cm ³
Jxt: 34,8074 Cm ⁴	Jxt: 34,8074 Cm ⁴
Wxt: 9,9330 Cm ³	Wxt: 9,9330 Cm ³

Janela de Correr 2 e 4 Folhas

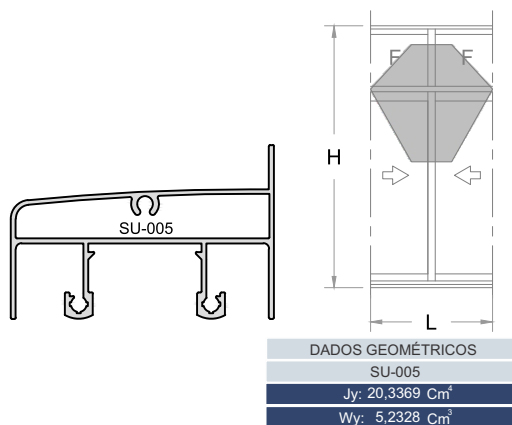
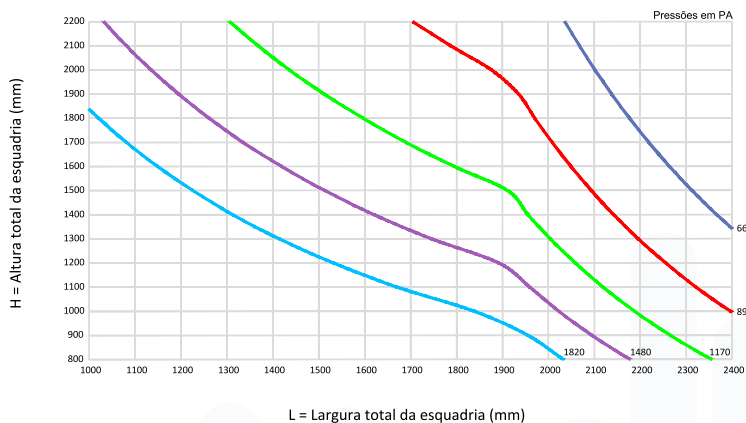

Tensão Admissível: 7 Kg/mm² (Liga 6060-T5)
 Flecha Admissível: L/ 175 ou 30mm

Notas:
 Atenção a deformação pelo peso próprio da estrutura.

Janela de Correr 2 e 4 Folhas

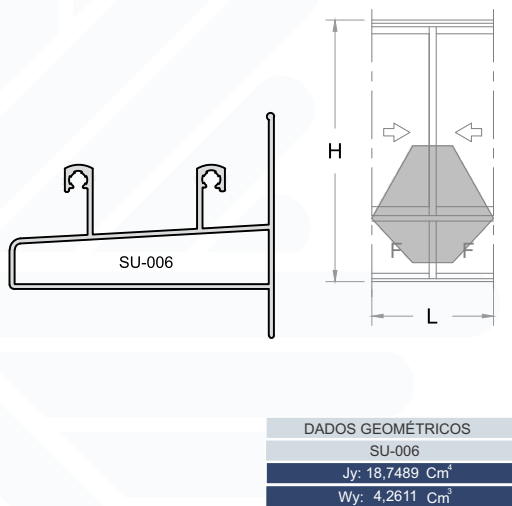
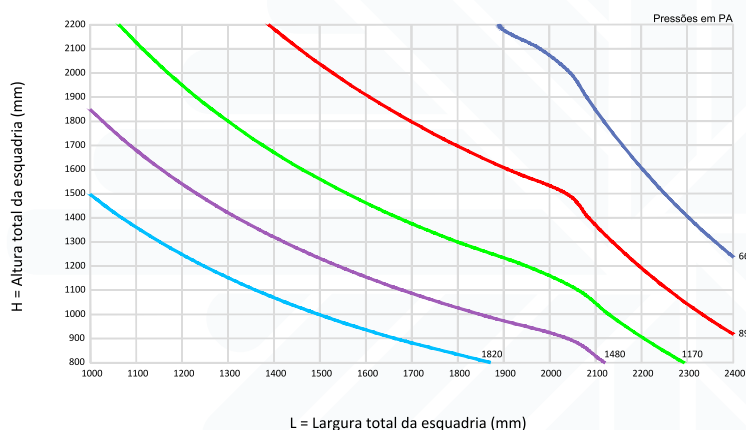

Tensão Admissível: 7 Kg/mm² (Liga 6060-T5)
 Flecha Admissível: L/ 175 ou 30mm

Notas:
 Atenção a deformação pelo peso próprio da estrutura.

Janela de Correr 2 e 4 Folhas

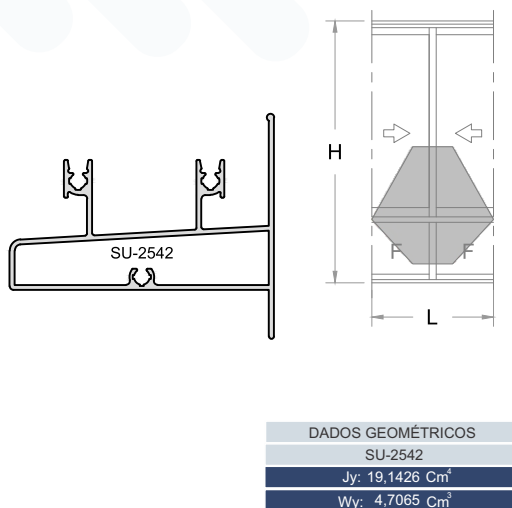
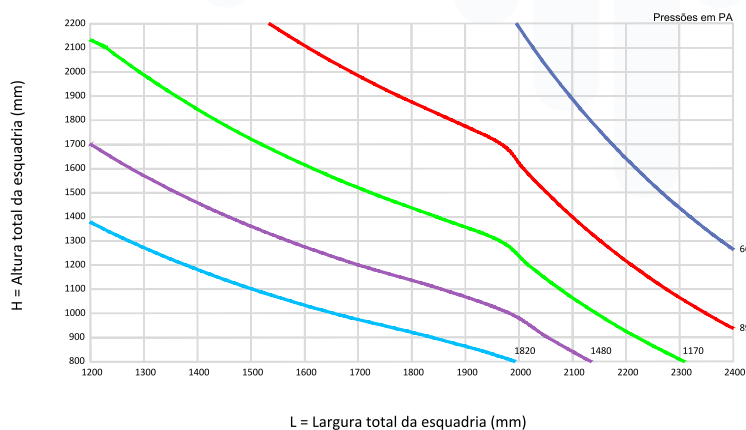

Tensão Admissível: 7 Kg/mm² (Liga 6060-T5)
 Flecha Admissível: L/ 175 ou 30mm

Notas:
 Atenção a deformação pelo peso próprio da estrutura.

SISTEMA DE ESQUADRIAS LAGUNA 25

REV05

Maxim-ar / Fixo

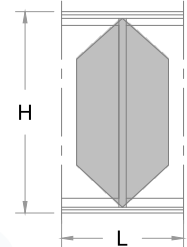
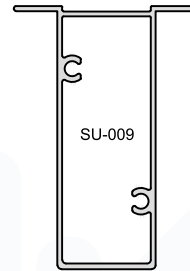
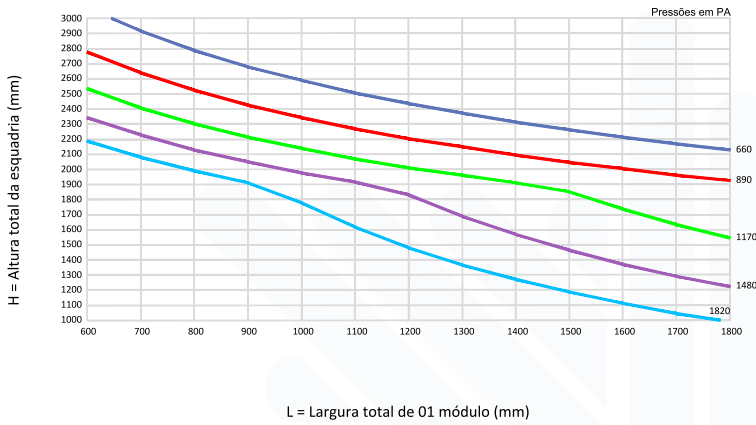

DADOS GEOMÉTRICOS	
SU-009	
Jx:	18,9853 Cm ⁴
Wx:	5,0629 Cm ³

Tensão Admissível: 7 Kg/mm² (Liga 6060-T5)

Flecha Admissível: H/ 175 ou 30mm

Maxim-ar / Fixo

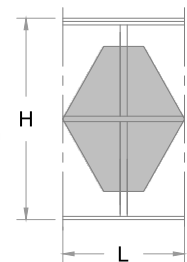
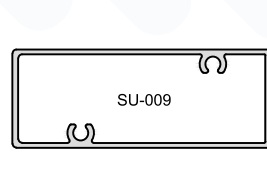
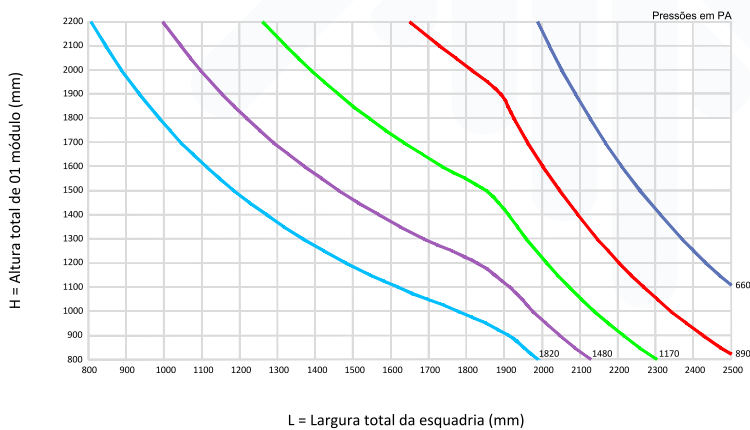

DADOS GEOMÉTRICOS	
SU-009	
Jy:	18,9853 Cm ⁴
Wy:	5,0629 Cm ³

Tensão Admissível: 7 Kg/mm² (Liga 6060-T5)

Flecha Admissível: L/ 175 ou 30mm

Notas:
Atenção a deformação pelo peso próprio da estrutura.

Maxim-ar / Fixo

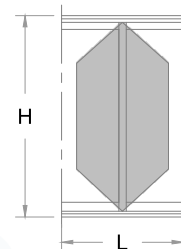
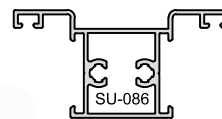
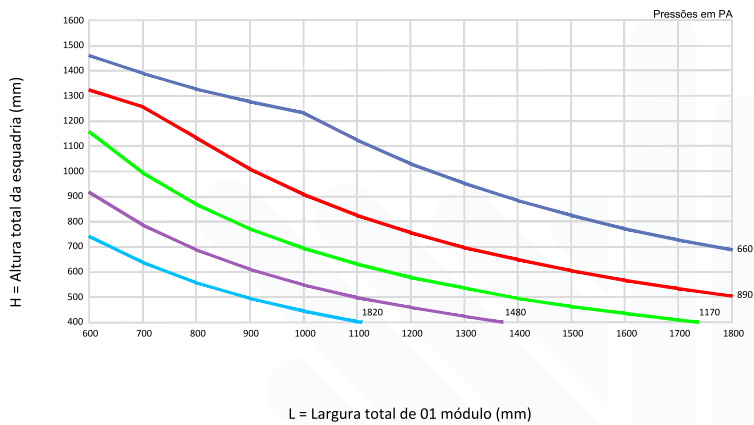

DADOS GEOMÉTRICOS	
SU-086	
Jx:	2,0541 Cm ⁴
Wx:	1,2668 Cm ³

Tensão Admissível: 7 Kg/mm² (Liga 6060-T5)

Flecha Admissível: H/ 175 ou 30mm

Maxim-ar / Fixo

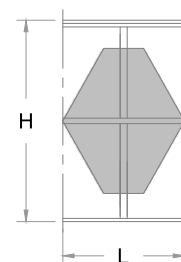
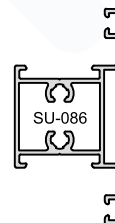
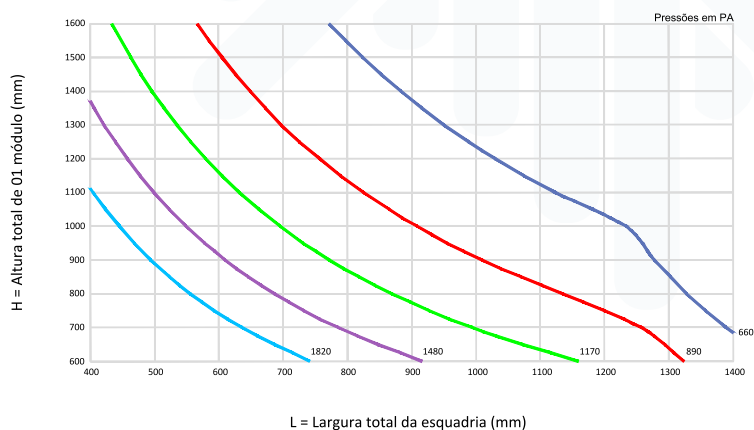

DADOS GEOMÉTRICOS	
SU-086	
Jy:	2,0541 Cm ⁴
Wy:	1,2668 Cm ³

Tensão Admissível: 7 Kg/mm² (Liga 6060-T5)

Flecha Admissível: L/ 175 ou 30mm

Notas:
Atenção a deformação pelo peso próprio da estrutura.

Janelas De Correr

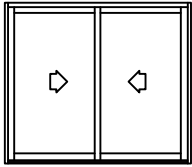

Janela de Correr 2 Folhas

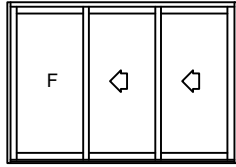

Janela de Correr 3 Folhas

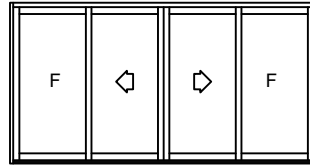

Janela de Correr 4 Folhas

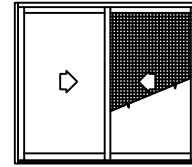

Janela de Correr 3 Folhas Com Mosquiteira

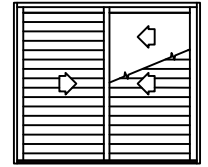

Janela de Correr 3 Folhas Com Mosquiteira

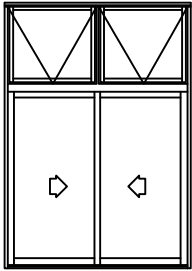

Janela de Correr 2 Folhas Com Bandeira

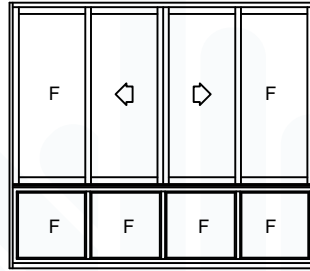

Janela de Correr 4 Folhas Com Peitoril

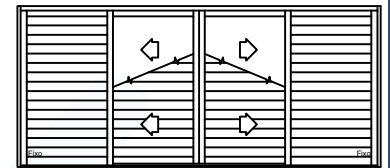

Janela de Correr 6 Folhas Com Veneziana e Vidro

Janelas Maxim Ar

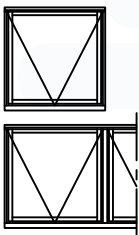

Janela Maxim-ar 'N' Módulos

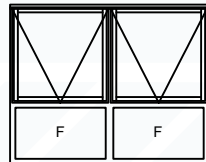

Janela Maxim-ar Com Peitoril

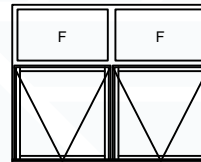

Janela Maxim-ar Com Bandeira

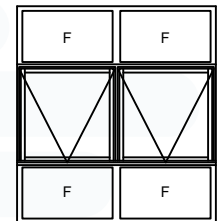

Janela Maxim-ar Com Bandeira e Peitoril

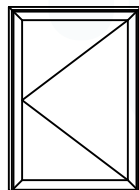

Portinhola 1 Folha Com Vidro

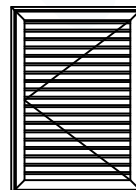

Portinhola 1 Folha Com Veneziana

Portas De Correr

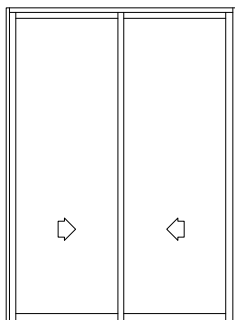

Porta de Correr
2 Folhas
Sem Travessa

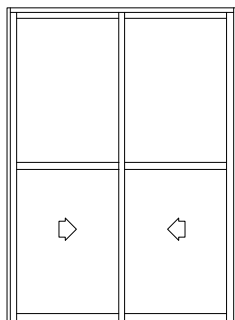

Porta de Correr
2 Folhas
Com Travessa

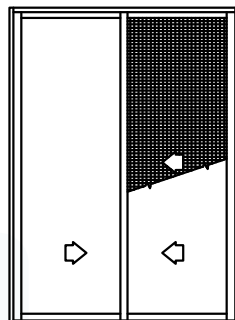

Porta de Correr
3 Folhas
Com Mosquiteira

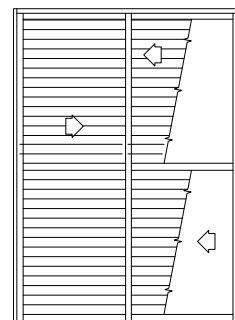

Porta de Correr 3 Folhas
Com Travessa
Com Vidro e Venezianas

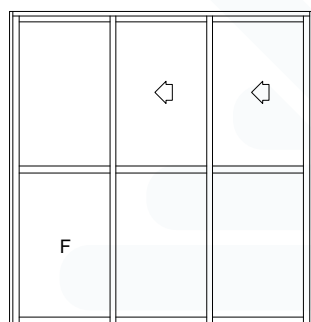

Porta de Correr 3 Folhas
Com e Sem Travessa

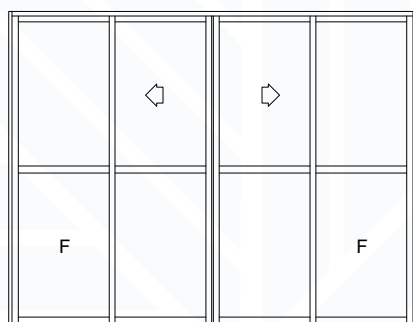

Porta de Correr 4 Folhas
Com e Sem Travessa

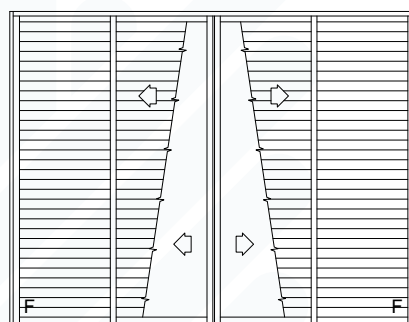

Porta de Correr 6 Folhas
Com e Sem Travessa
Com Vidros e Venezianas

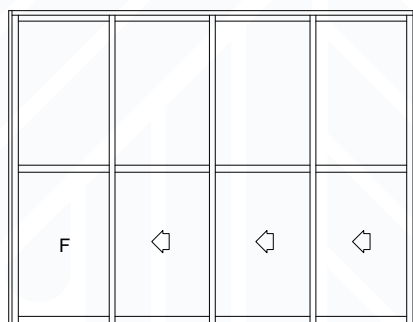

Porta de Correr 4 Folhas
Com e Sem Travessa

Portas De Giro

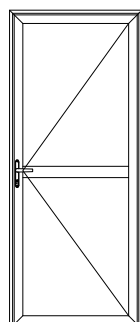

Porta de Giro 1 Folhas
Com e Sem Travessa

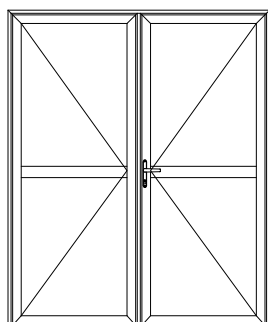

Porta de Giro 2 Folhas
Com e Sem Travessa

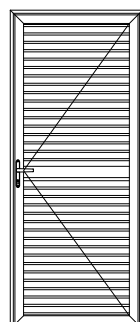

Porta de Giro 1 Folhas
Com e Sem Travessa
Com Veneziana ou Lambri

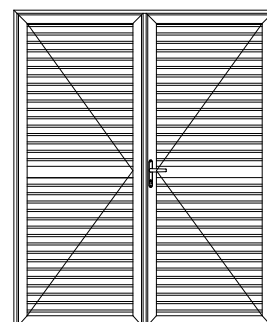

Porta de Giro 2 Folhas
Com e Sem Travessa
Com Veneziana ou Lambri

ÍNDICE DE PERFIS

Código	Descrição	Página	Código	Descrição	Página
25-002	Marco Portinhola	44	SU-108	Complemento - Veneziana	48
25-016	Folha Perimetral - Portinhola	45	SU-111	Folha Perimetral - Porta de Giro	46
25-514	Marco Lateral	44	SU-121	Marco Superior Horizontal	33
25-540	Marco Tubular - Porta de Giro	46	SU-123	Marco Lateral Vertical	33
25-541	Coluna / Travessa	46	SU-186	Folha Inferior e Superior S/Baguete	38
25-542A	Folha Perimetral - Porta de Giro	45	SU-187A	Folha Superior e Inferior Horizontal - Veneziana	41
25-548	Batente - Porta de Giro	46	SU-188	Travessa Central 50mm S/Baguete	38
ADI-016	Chumbador para Contramarco	20	SU-200	Folha Inferior e Lateral -Maxim-ar	43
ADI-017	Arremate Vertical e Horizontal	23	SU-203	Baguete Terminal - Veneziana	47
ADI-349	Arremate Vertical e Horizontal	22	SU-203A	Complemento - Veneziana	48
BG-001	Baguete Vertical e Horizontal	45	SU-225	Folha Inferior Horizontal	34
CL-006	Cantoneira de Ligação 45o	20	SU-226	Folha Inferior Horizontal S/Baguete	38
CL-011	Cunha de Ligação 45o	20	SU-227	Travessa 60mm	34
CM-060A	Contramarco	21	SU-228	Marco Inferior Horizontal	27
CM-098	Contramarco Inferior - Portas	21	SU-230	Marco Inferior Horizontal	31
CM-151	Contramarco Inferior - Portas	21	SU-292	Inverso de Baguete	42
CM-173	Contramarco	22	SU-246A	Folha Superior e Inferior Horizontal	34
CM-174	Contramarco	22	SU-2522	Marco Inferior Horizontal	26
CM-200A	Contramarco	21	SU-2523	Marco Inferior Horizontal	27
IT-100	Arremate Vertical e Horizontal	23	SU-2541	Marco Inferior Horizontal	26
IT-101	Arremate Vertical e Horizontal	23	SU-2542	Travessa Intermediária -Peitoril	27
IT-102	Arremate Vertical e Horizontal	24	SU-2567	Folha Mão de Amigo Central	36
LB-035	Lambri Liso	51	SU-2569	Marco Inferior Horizontal	33
LB-050	Lambri Frisado	51	SU-258	Click Trilho	29
LB-061	Lambri Duplo - Liso	52	SU-2586	Folha Lateral Vertical C/ Reforço	28
LG-037	Veneziana - Ventilação Permanente	50	SU-2590	Folha Lateral Vertical S/Baguete C/Reforço	35
ME-013	Arremate de Piso	24	SU-2592	Folha Lateral Vertical S/Baguete C/Reforço	39
SU-001	Marco Superior Horizontal	25	SU-2621	Marco Inferior Horizontal	39
SU-002	Marco Inferior Horizontal	26	SU-2622	Marco Inferior Horizontal	30
SU-003	Marco Lateral Vertical	28	SU-280	Folha Lateral Vertical C/Reforço	31
SU-004	Marco Bandeira / Peitoril	25	SU-292	Inverso de Baguete	35
SU-005	Travessa Intermediária -Bandeira	25	TM-171	Quadro Mosquit	44
SU-006	Travessa Intermediária -Peitoril	27	VZ-024	Veneziana - Ventiladaeira	45
SU-007	Marco Lateral Vertical	28	VZ-024F	Veneziana Baixa - Cega	49
SU-008	Complemento do Marco Lateral	29	VZ-051	Veneziana Baixa - Ventilada	49
SU-009	Coluna	29	VZ-051F	Veneziana - Cega	49
SU-010	Marco Superior Horizontal	30	VZ-106	Veneziana - Ventilada	49
SU-011	Marco Inferior Horizontal	30	VZ-106F	Veneziana - Cega	40
SU-012	Marco Lateral Vertical	32			40
SU-013	Marco Lateral Vertical	32			
SU-014	Marco Lateral Vertical	32			
SU-018	Marco Bandeira / Peitoril	31			
SU-022	Marco Inferior Horizontal	26			
SU-039	Folha Lateral Vertical	35			
SU-040	Folha Mão de Amigo Interno	36			
SU-041	Folha Mão de Amigo Externo	36			
SU-044	Folha Mão de Amigo Externo C/ Reforço	37			
SU-047	Folha Mão de Amigo Interno C/ Reforço	37			
SU-052	Folha Lateral Vertical C/Reforço	35			
SU-053	Folha Superior e Inferior Horizontal	34			
SU-055	Folha Lateral Vertical S/Baguete	39			
SU-056	Folha Mão de Amigo S/Baguete	40			
SU-057	Folha Mão de Amigo Central S/Baguete	40			
SU-061	Folha Lateral Vertical S/Baguete C/Reforço	40			
SU-064	Folha Perimetral - Portinhola	45			
SU-065	Marco Portinhola	44			
SU-069	Folha Mão de Amigo Central-Veneziana	41			
SU-071	Complemento Marco	44			
SU-079	Marco Tubular - Maxim-ar	42			
SU-080	Folha Superior - Maxim-ar	43			
SU-083	Pingadeira -Maxim-ar	42			
SU-086	Coluna / Travessa	42			
SU-102A	Baguete Vertical e Horizontal	47			
SU-102B	Baguete Vertical	47			
SU-102C	Baguete Vertical e Horizontal	47			
SU-103A	Baguete do Marco Maxim-ar	48			
SU-103B	Baguete do Marco Maxim-ar	48			

Cantoneira de Ligação 45°

CL-006	1,028 kg/m
Medida Padrão	3000mm

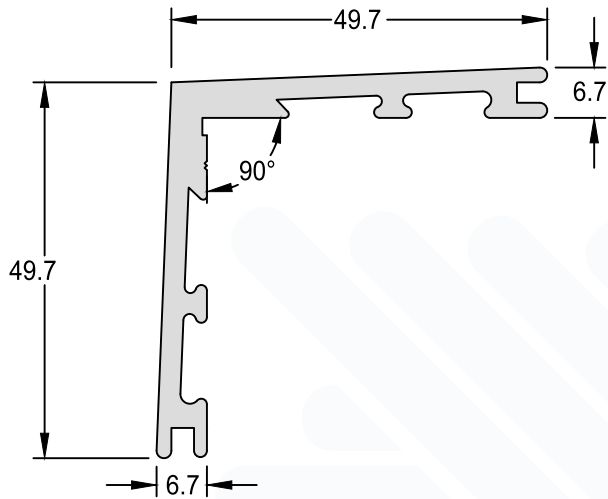

Cunha de Ligação 45°

CL-011	0,304 kg/m
Medida Padrão	3000mm

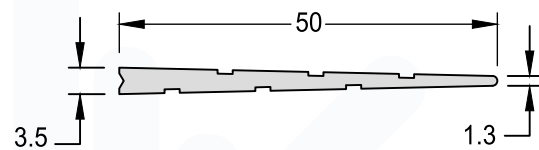

Chumbador para Contramarco

ADI-016	0,556 kg/m
---------	------------

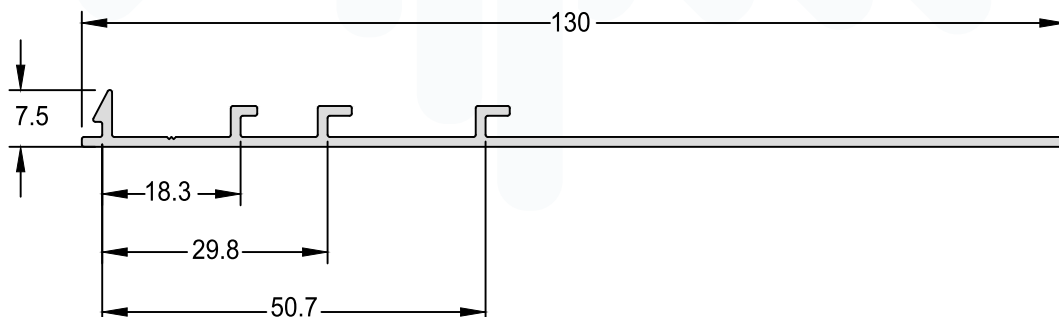

Contramarco

CM-200A 0,174 kg/m

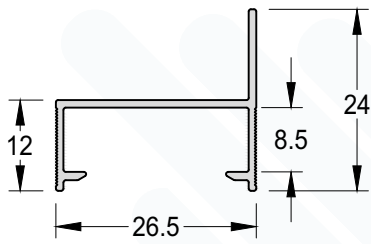

Contramarco Inferior - Portas

CM-151 0,241 kg/m

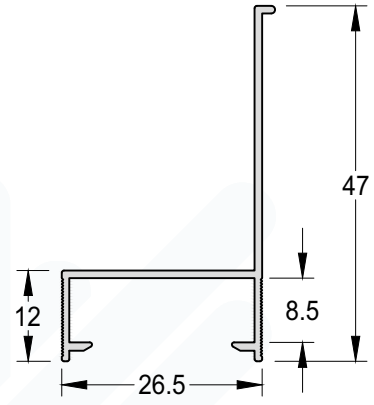

Contramarco

CM-060A 0,205 kg/m

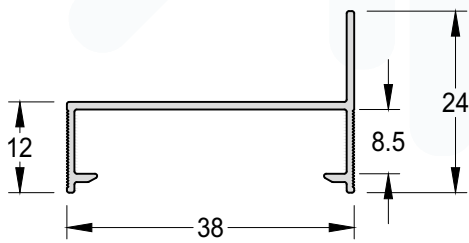

Contramarco Inferior - Portas

CM-098 0,277 kg/m

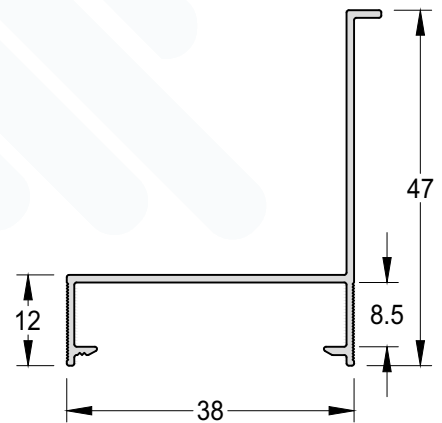

Contramarco

CM-174

0,336 kg/m

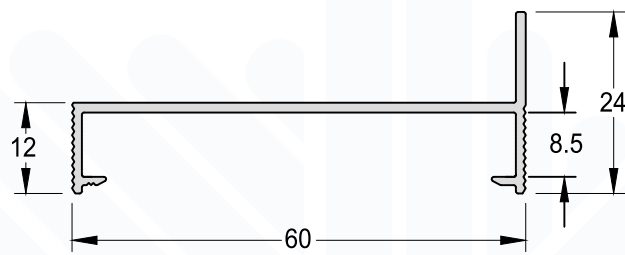

Contramarco

CM-173

0,423 kg/m

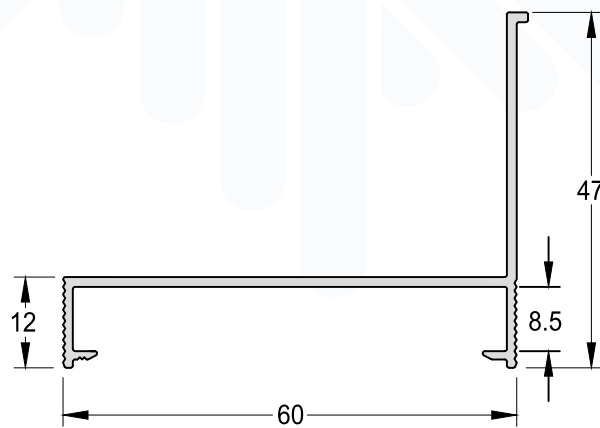

Arremate Vertical e Horizontal

ADI-017 0,165 kg/m

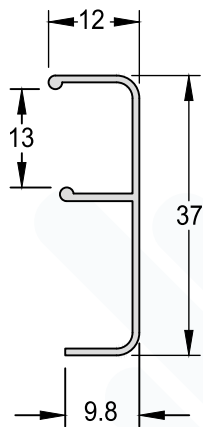

Arremate Vertical e Horizontal

IT-101 0,259 kg/m

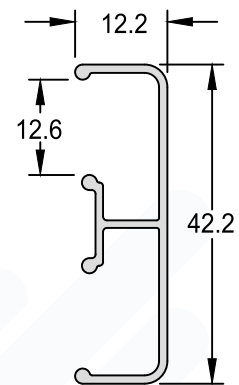

Arremate Vertical e Horizontal

IT-100 0,307 kg/m

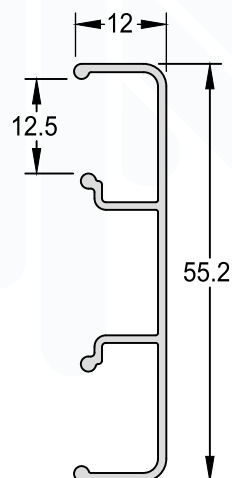

Arremate Vertical e Horizontal

ADI-349 0,276 kg/m

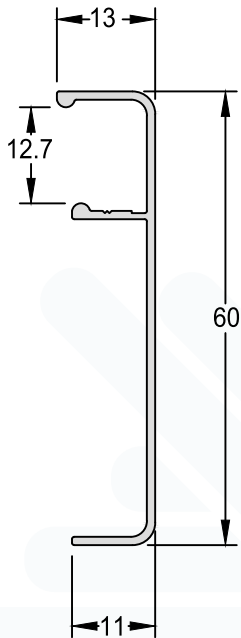

Arremate Vertical e Horizontal

IT-102 0,330 kg/m

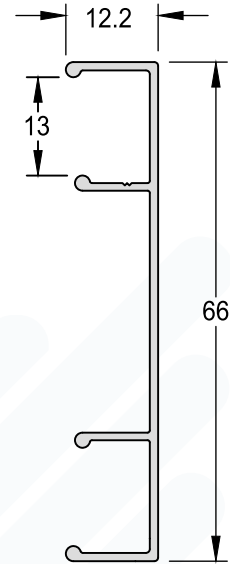

Arremate de Piso

ME-013 0,270 kg/m

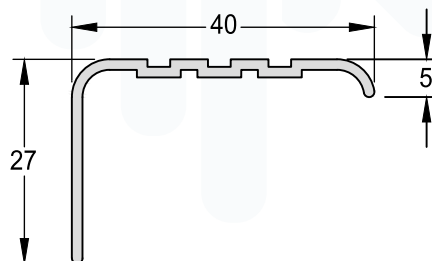

Marco Superior Horizontal
SU-001 0,737 kg/m

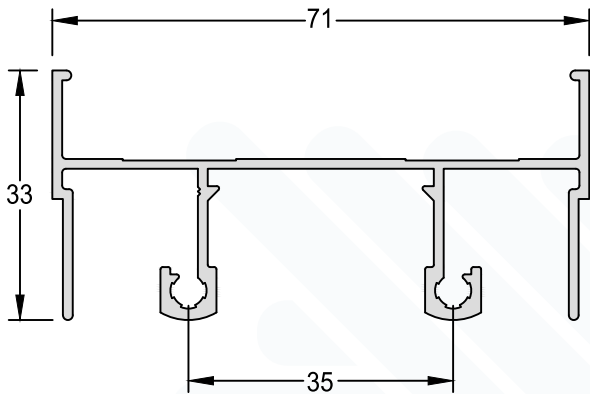
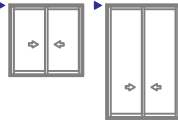

**Travessa Intermediária -
Bandeira**
SU-005 1,034 kg/m

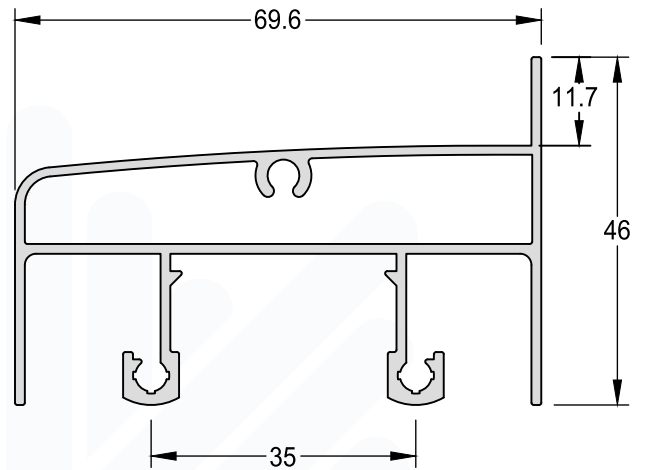
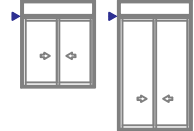

Marco Bandeira / Peitoril
SU-004 0,481 kg/m

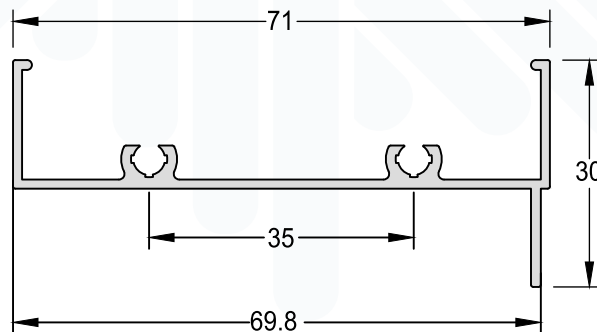

Marco Inferior Horizontal

SU-002 0,700 kg/m

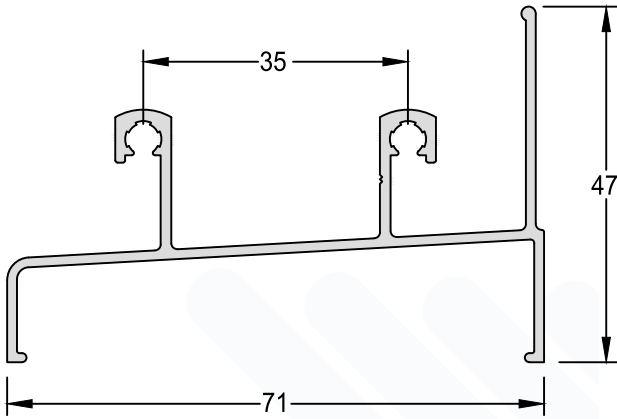

Marco Inferior Horizontal

SU-2541 0,725 kg/m



Encaixe: NYL2586/ SU-258

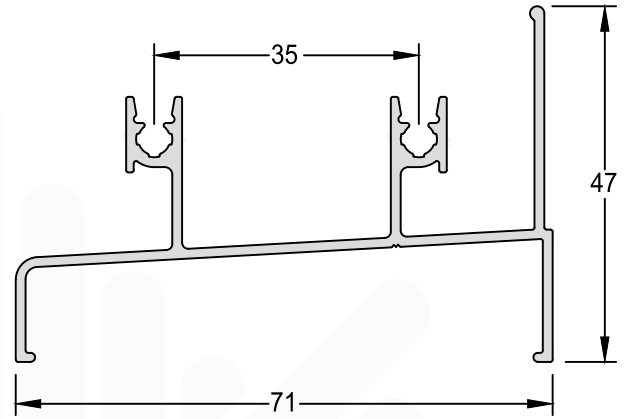

Marco Inferior Horizontal

SU-022 0,770 kg/m

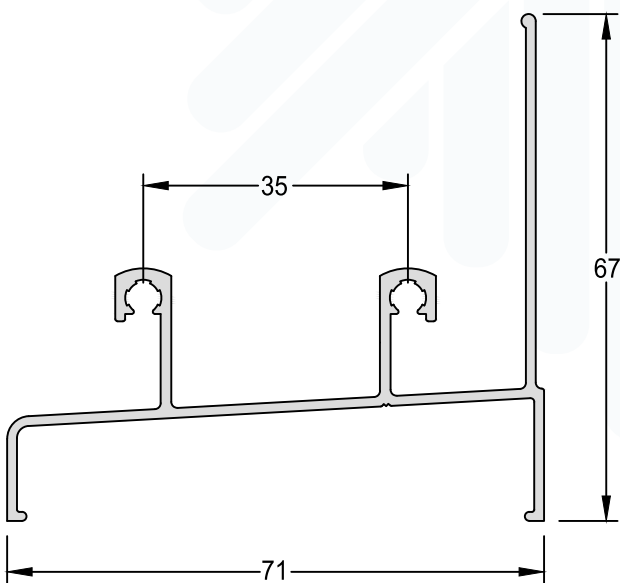

Marco Inferior Horizontal

SU-2522 0,796 kg/m



Encaixe: NYL2586/ SU-258

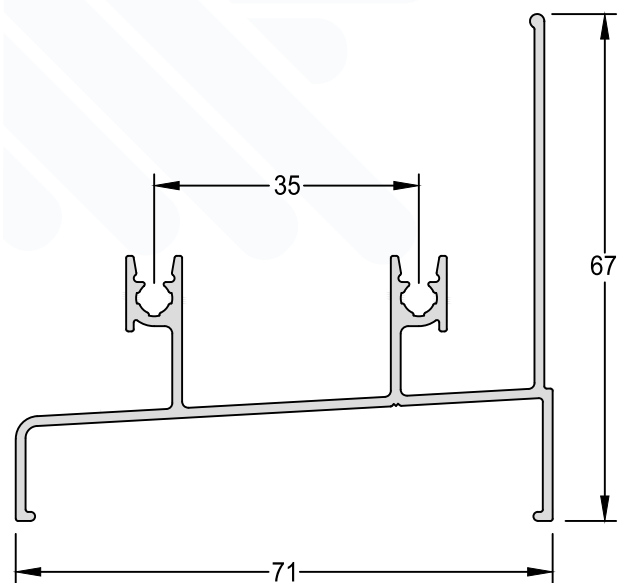

Marco Inferior Horizontal

SU-228 0,665 kg/m

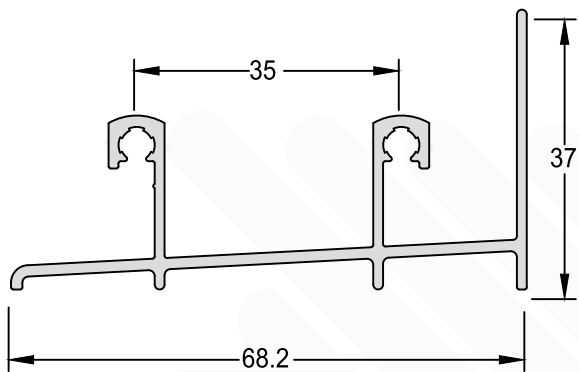

Marco Inferior Horizontal

SU-2523 0,697 kg/m

Encaixe: NYL2586/ SU-258

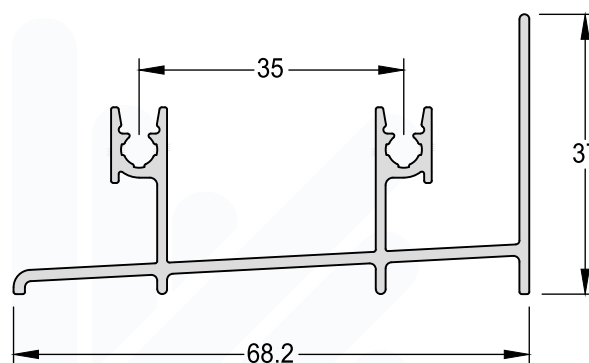

**Travessa Intermediária -
Peitoril**

SU-006 0,968 kg/m

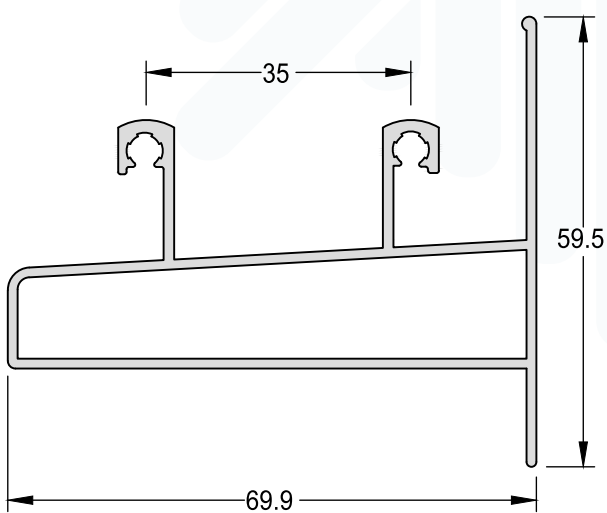

**Travessa Intermediária -
Peitoril**

SU-2542 1,022 kg/m

Encaixe: NYL2586/ SU-258

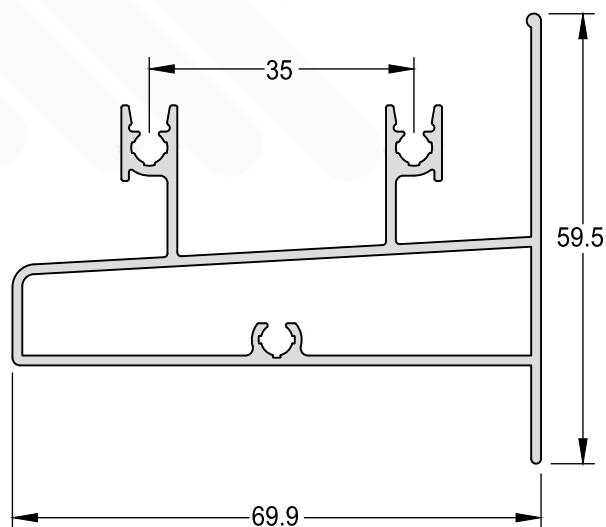

Marco Lateral Vertical

SU-003

0,521 kg/m

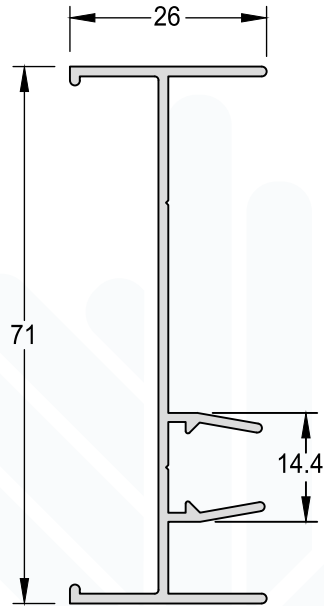
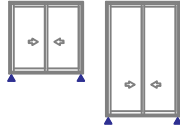

Marco Lateral Vertical

SU-007

0,380 kg/m

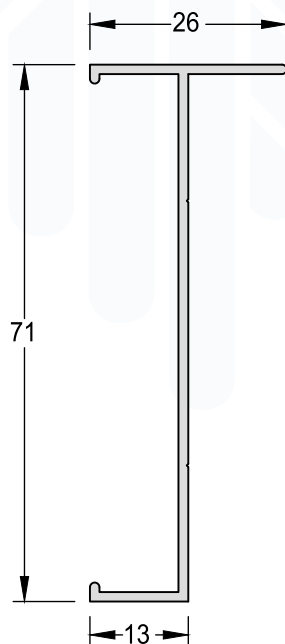
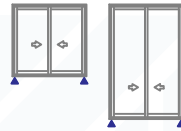

Click Trilho

SU-258 0,059 kg/m

Encaixe: SU-2522/ SU-2523/ SU-2541/ SU-2542/
SU-2569/ SU-2621/ SU-2622

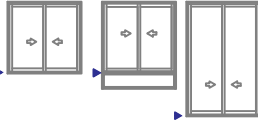

Complemento do Marco Lateral

SU-008 0,261 kg/m

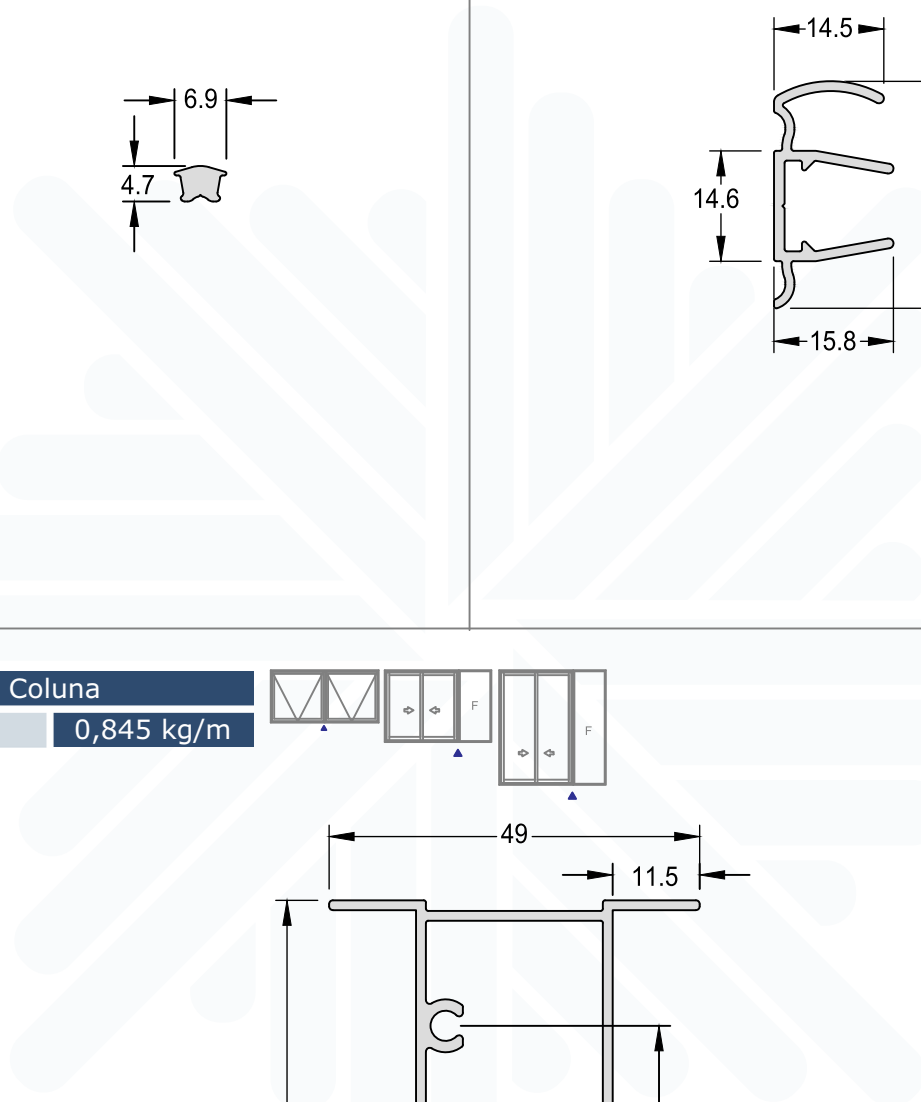
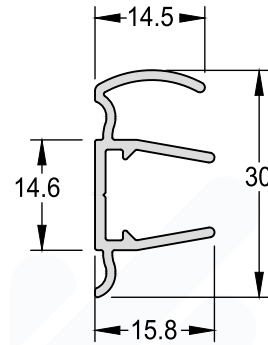
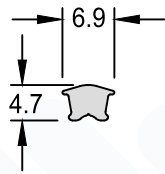
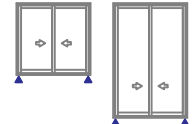

Coluna

SU-009 0,845 kg/m

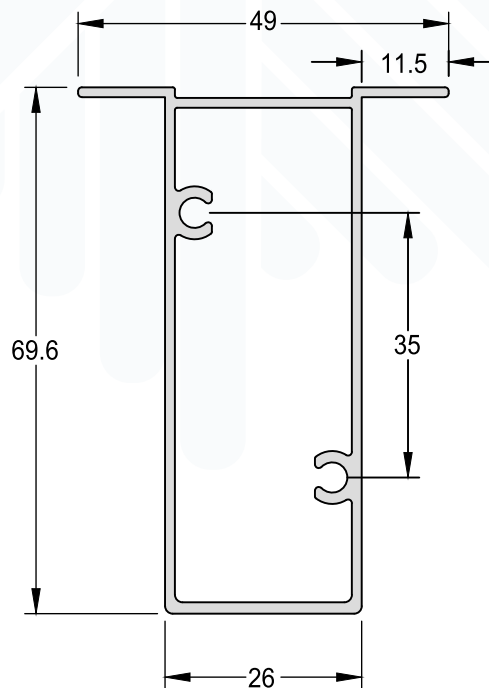

Marco Superior Horizontal

SU-010 0,985 kg/m

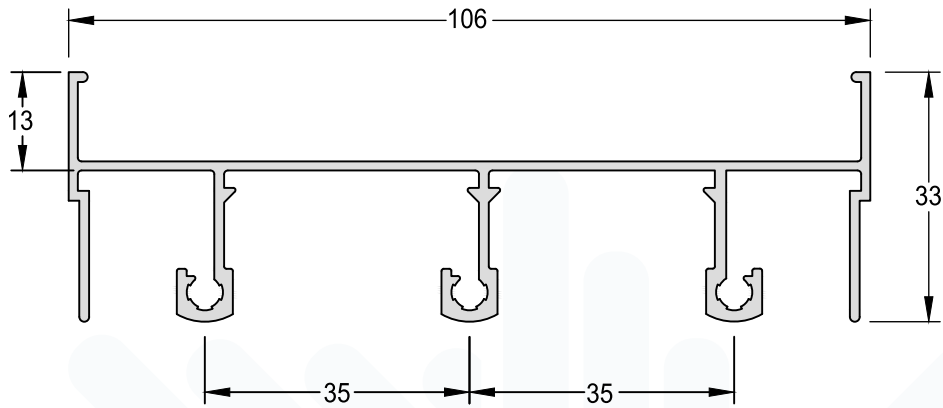
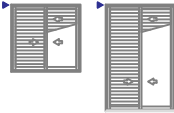

Marco Inferior Horizontal

SU-011 0,933 kg/m

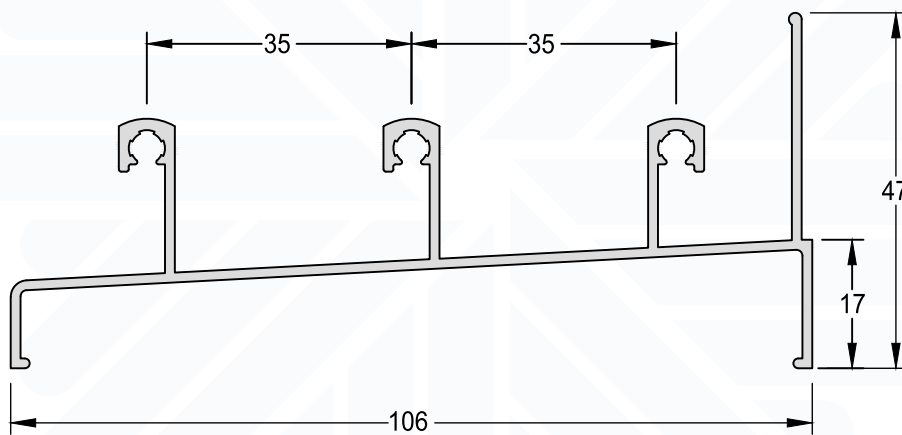

Marco Inferior Horizontal

SU-2621 0,984 kg/m

Encaixe: NYL2586/ SU-258

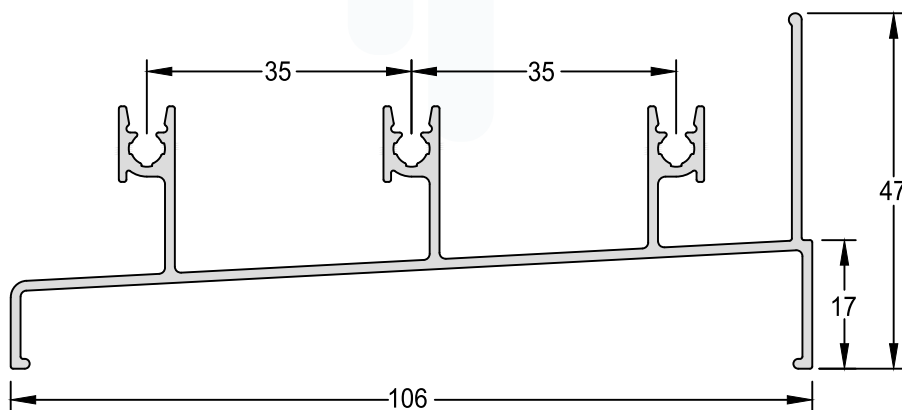

Marco Bandeira / Peitoril

SU-018

0,601 kg/m

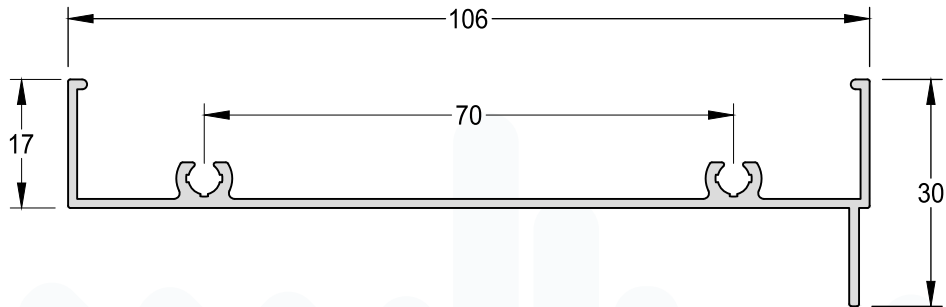
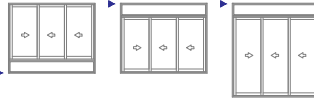

Marco Inferior Horizontal

SU-230

0,930 kg/m

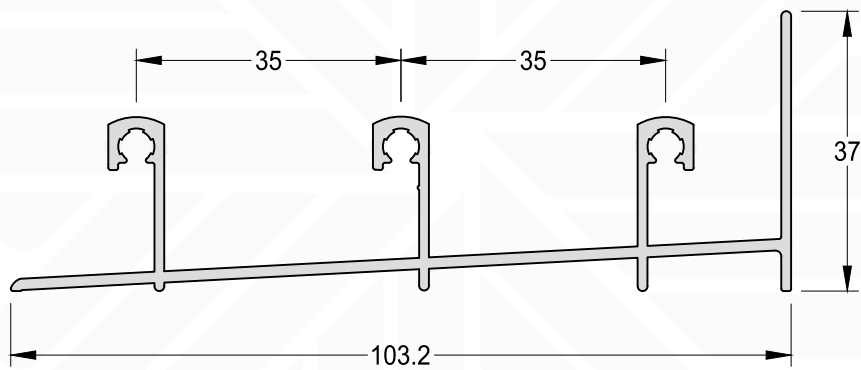

Marco Inferior Horizontal

SU-2622

0,978 kg/m

Encaixe: NYL2586/ SU-258

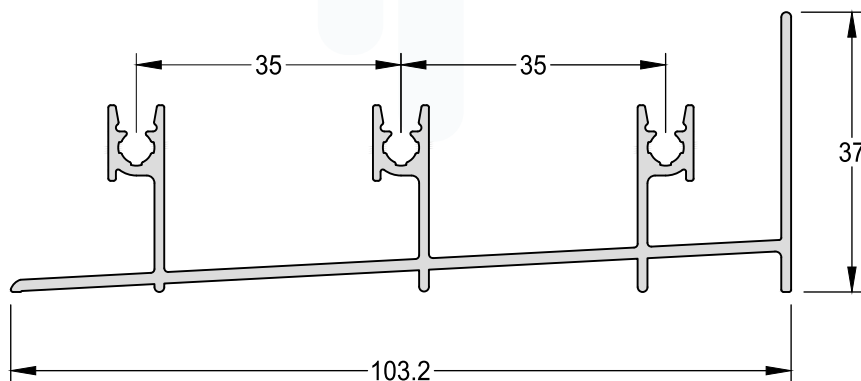
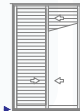

Marco Lateral Vertical

SU-013

0,784 kg/m

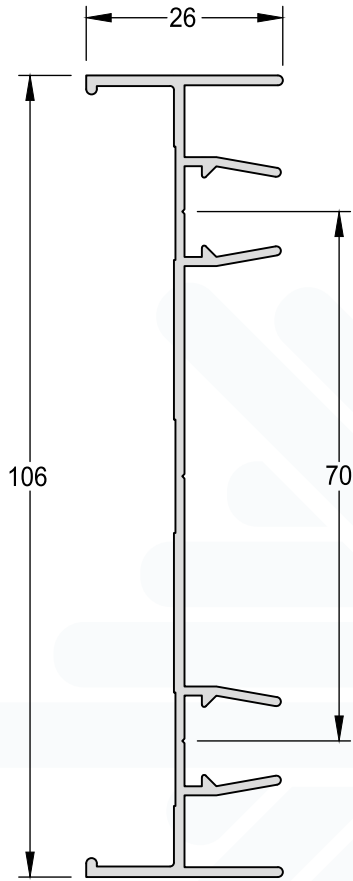

Marco Lateral Vertical

SU-014

0,671 kg/m

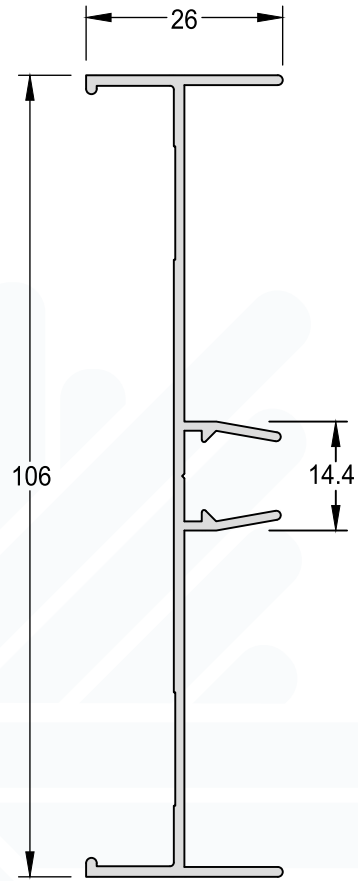

Marco Lateral Vertical

SU-012

0,536 kg/m

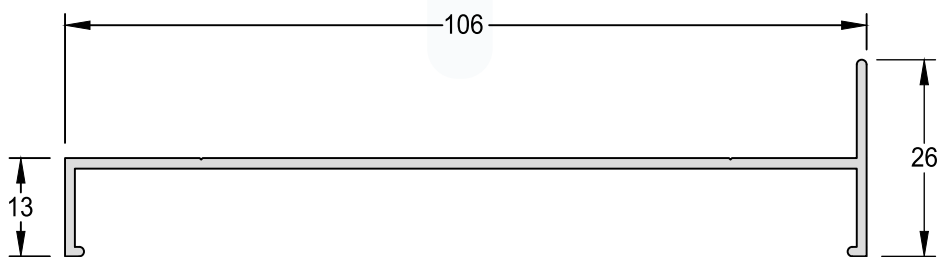

Marco Lateral Vertical

SU-123

0,733 kg/m

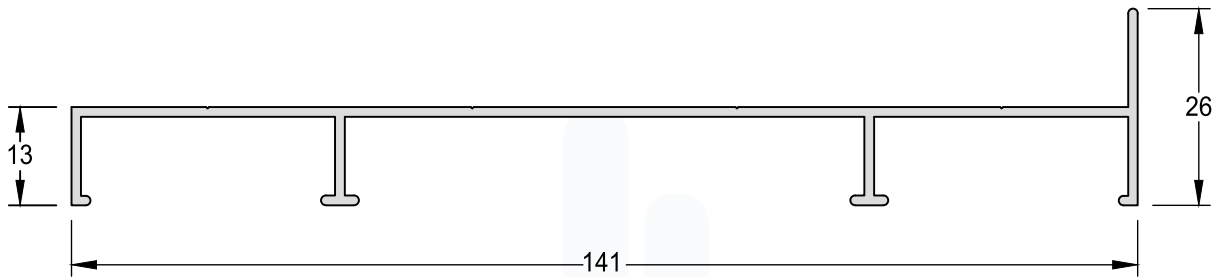
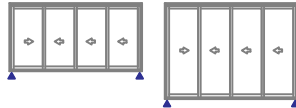

Marco Superior Horizontal

SU-121

1,227 kg/m

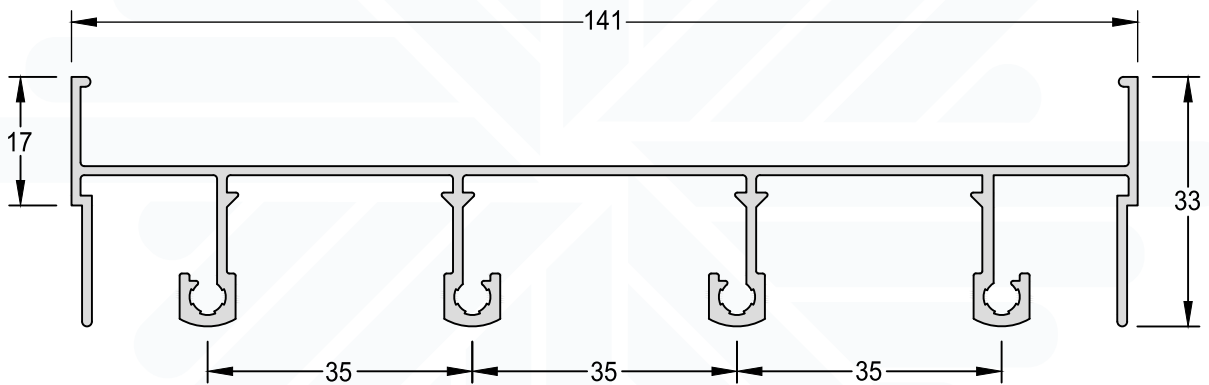

Marco Inferior Horizontal

SU-2569

1,396 kg/m

Encaixe: NYL2586/ SU-258

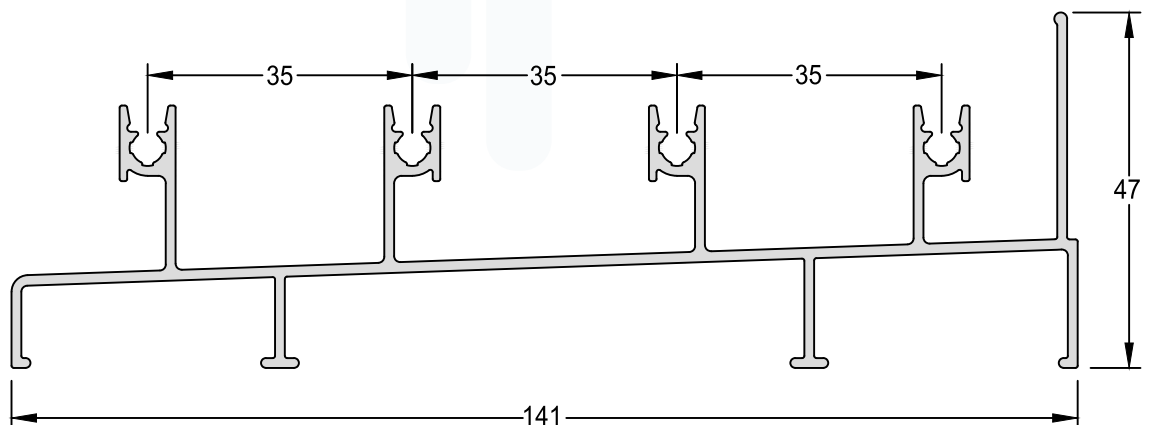

Folha Superior e Inferior Horizontal

SU-053 0,476 kg/m

Encaixe: SU-102A / SU-102C / SU-203 / SU-203A

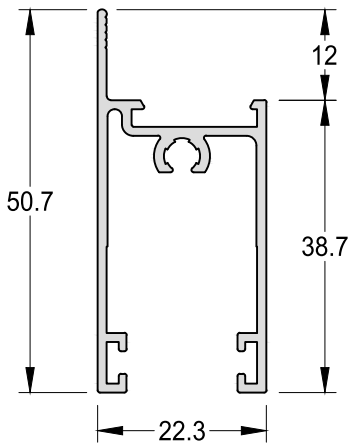
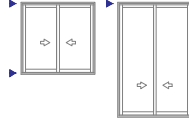

Folha Superior e Inferior Horizontal

SU-246A 0,646 kg/m

Encaixe: SU-102A / SU-102C / SU-203 / SU-203A

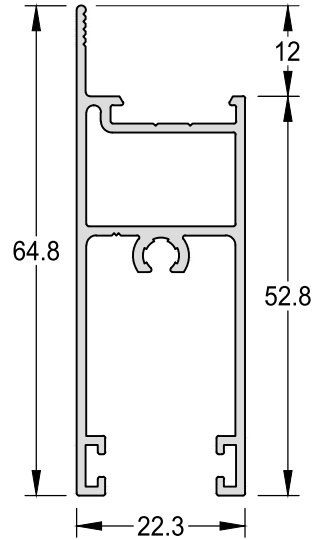
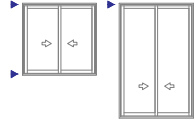

Folha Inferior Horizontal

SU-225 0,954 kg/m

Encaixe: SU-102A / SU-102C / SU-203 / SU-203A

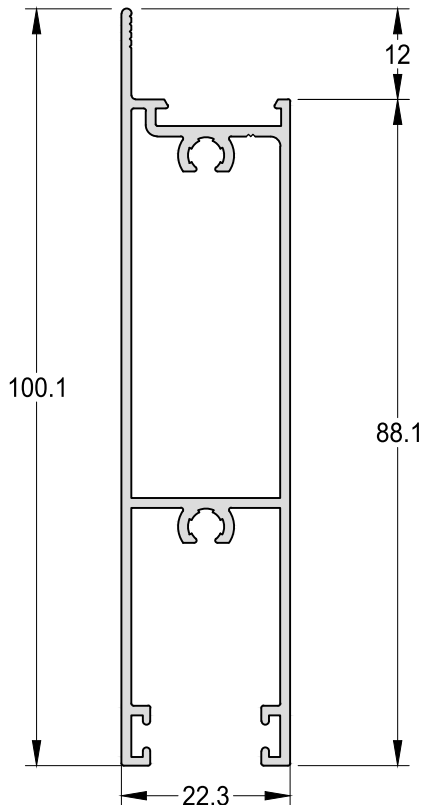

Travessa 60mm

SU-227 0,543 kg/m

Encaixe: SU-102A / SU-102C / SU-203 / SU-203A

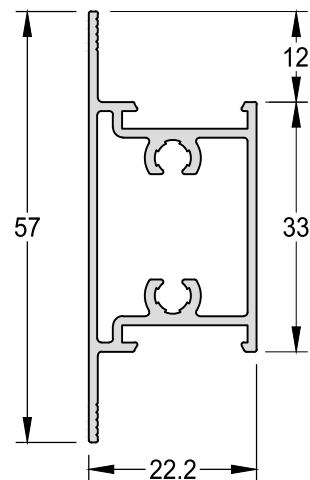

Folha Lateral Vertical

SU-039 0,476 kg/m

Encaixe: SU-102A/ SU-102B/ SO-102C/ SU-108

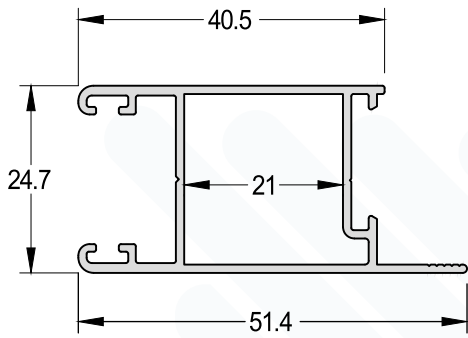

Folha Lateral Vertical C/Reforço

SU-280 0,620 kg/m

Encaixe: SU-102A/ SU-102B/ SU-102C/ SU-108

Medida Padrão 4600mm/ 6000mm

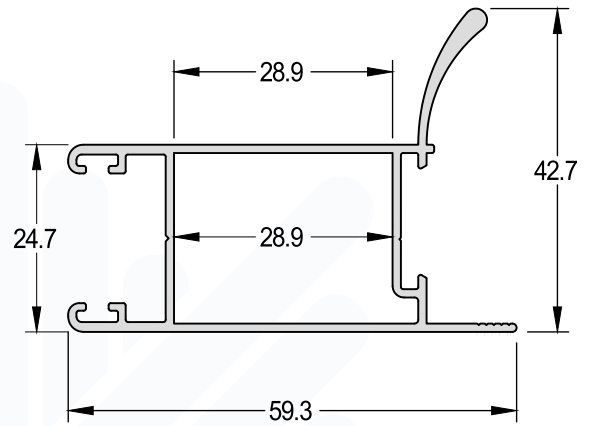
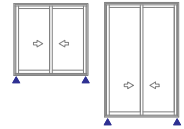

Folha Lateral Vertical C/Reforço

SU-052 0,757 kg/m

Encaixe: SU-102A/ SU-102B/ SU-102C/ SU-108

Medida Padrão 4600mm/ 6000mm

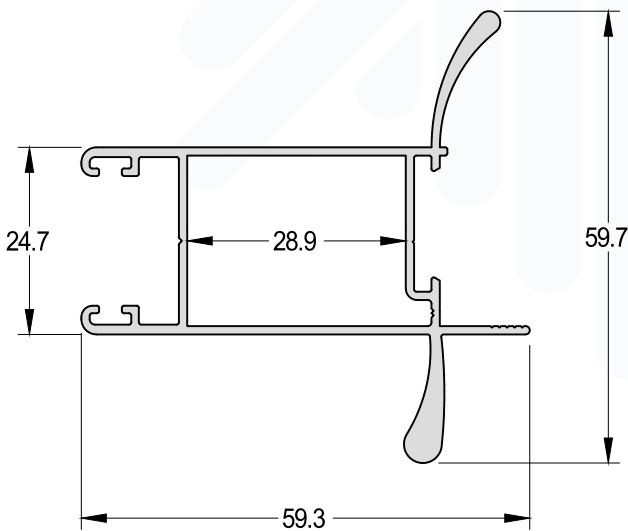
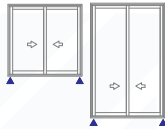

Folha Lateral Vertical C/Reforço

SU-2586 0,935 kg/m

Encaixe: SU-102A/ SU-102B/ SU-102C/ SU-108

Medida Padrão 4600mm/ 6000mm

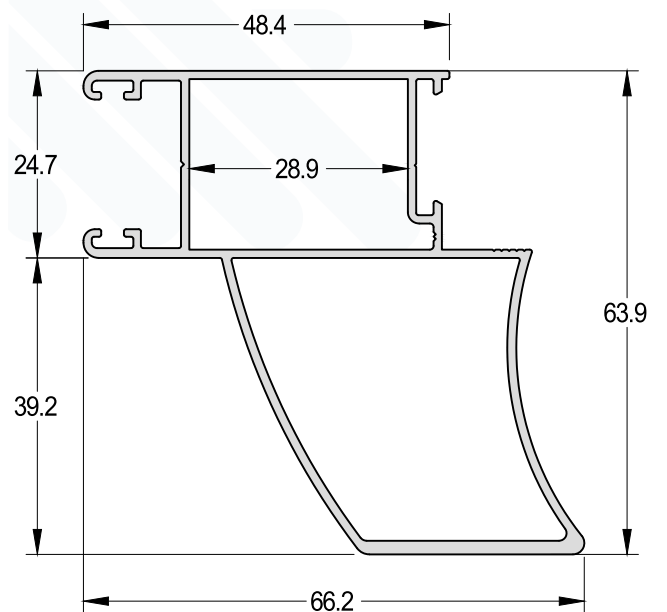
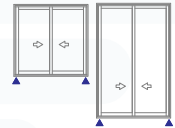

Folha Mão de Amigo Central

SU-2567 0,578 kg/m

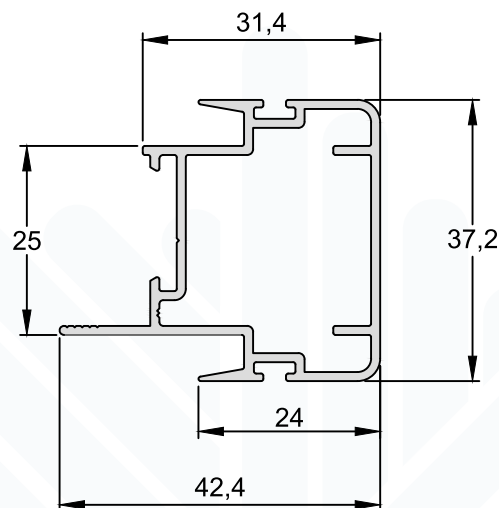
 Encaixe: SU-102A/ SU-102B/ SU-102C/
 SU-108

Folha Mão de Amigo Interno

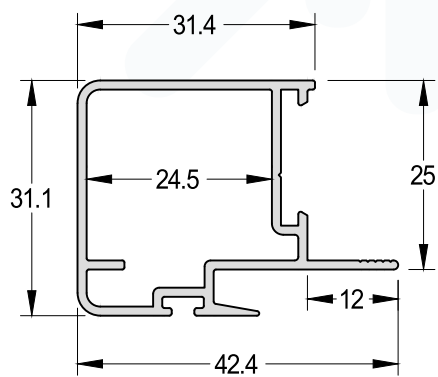
SU-040 0,489 kg/m

 Encaixe: SU-102A/ SU-102B/ SU-102C/
 SU-108

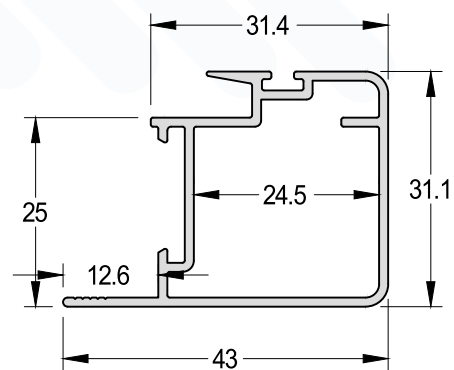
Folha Mão de Amigo Externo

SU-041 0,492 kg/m

 Encaixe: SU-102A/ SU-102B/ SU-102C/
 SU-108

**Folha Mão de Amigo Interno
C/Reforço**

SU-047 0,935 kg/m

Encaixe: SU-102A/ SU-102B/ SU-102C/
SU-108

Medida Padrão 4600mm/ 6000mm

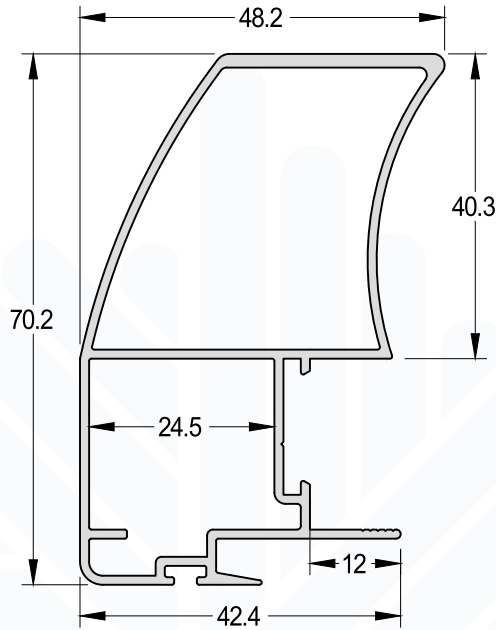
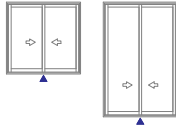

**Folha Mão de Amigo Externo
C/Reforço**

SU-044 0,899 kg/m

Encaixe: SU-102A/ SU-102B/ SU-102C/
SU-108

Medida Padrão 4600mm/ 6000mm

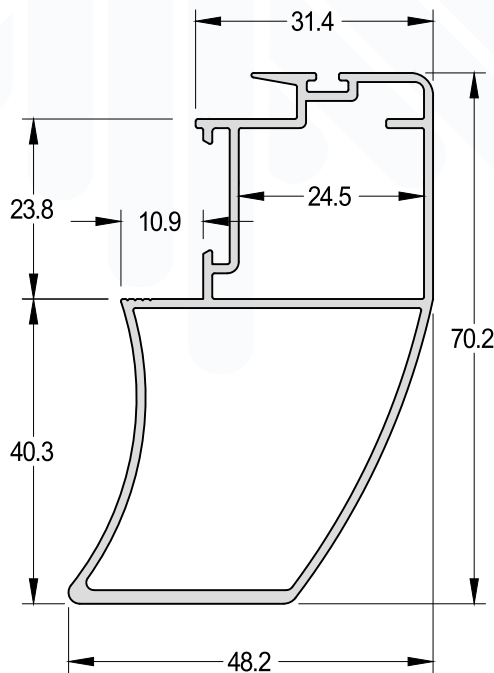
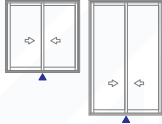

Folha Inferior e Superior
S/Baguete

SU-186 0,498 kg/m

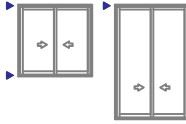

Travessa Central 50mm
S/Baguete

SU-188 0,573 kg/m

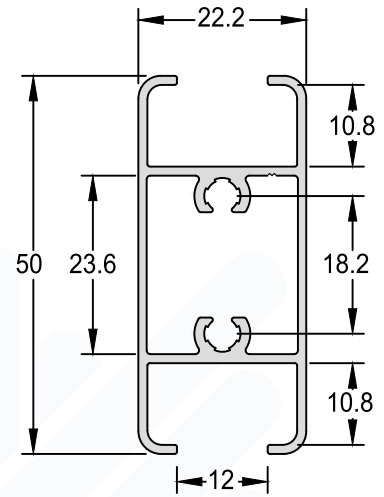
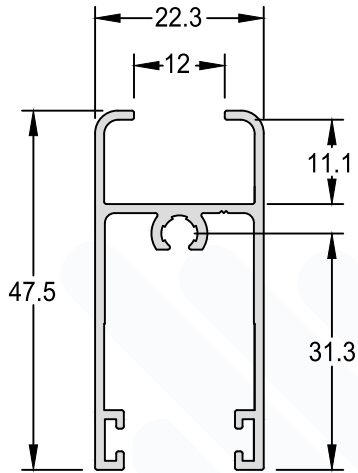

Folha Inferior Horizontal
S/Baguete

SU-226 0,970 kg/m

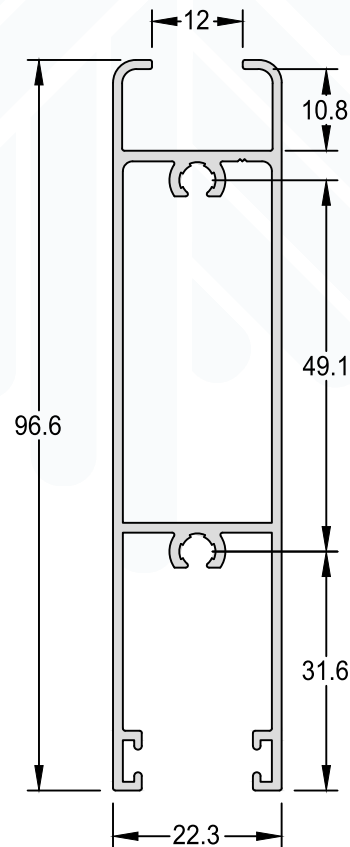

**Folha Lateral Vertical
S/Baguete**

SU-055 0,502 kg/m

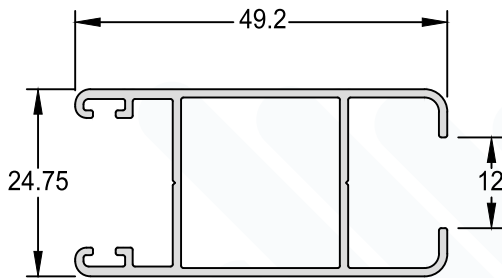
**Folha Lateral Vertical
S/Baguete C/Reforço**

SU-2590 0,642 kg/m

Medida Padrão 4600mm/6000mm

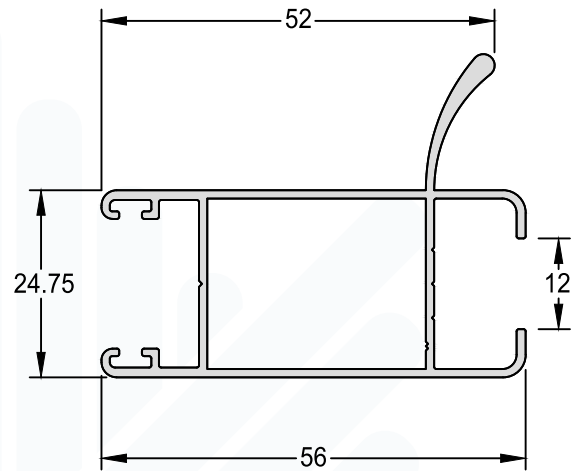
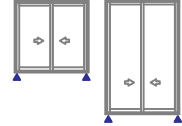
**Folha Lateral Vertical
S/Baguete C/Reforço**

SU-2592 0,961 kg/m

Medida Padrão 4600mm/6000mm

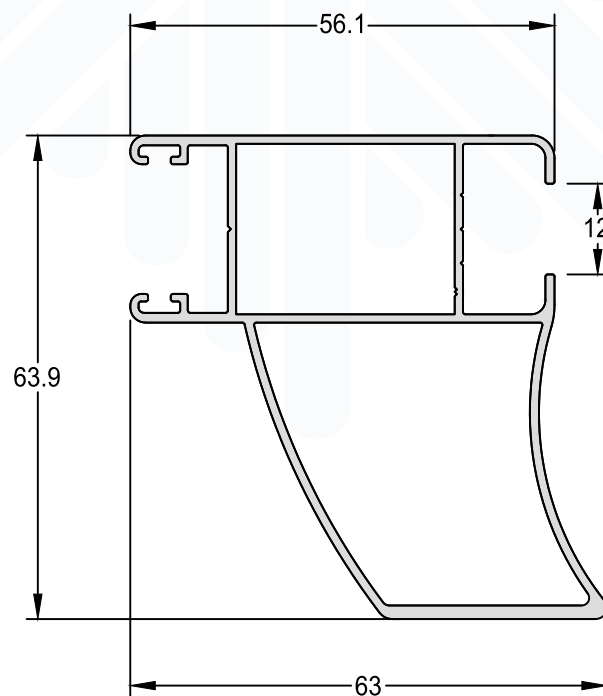
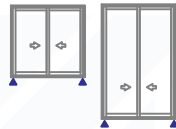

Folha Mão de Amigo
S/Baguete

SU-056 0,517 kg/m

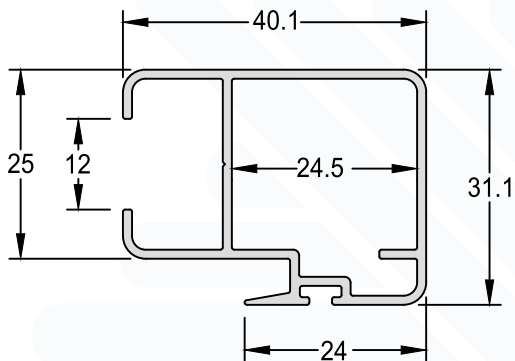

Folha Lateral Vertical
S/Baguete C/Reforço

SU-061 0,962 kg/m
Medida Padrão 4600mm/6000mm

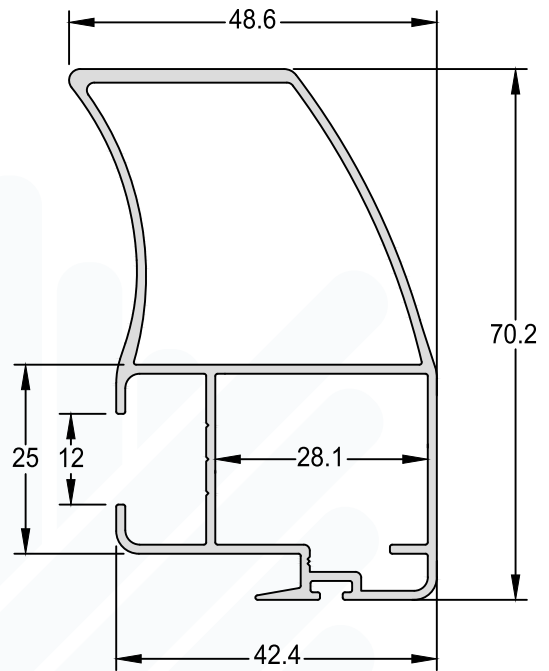
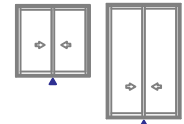

Folha Mão de Amigo
Central S/Baguete

SU-057 0,620 kg/m

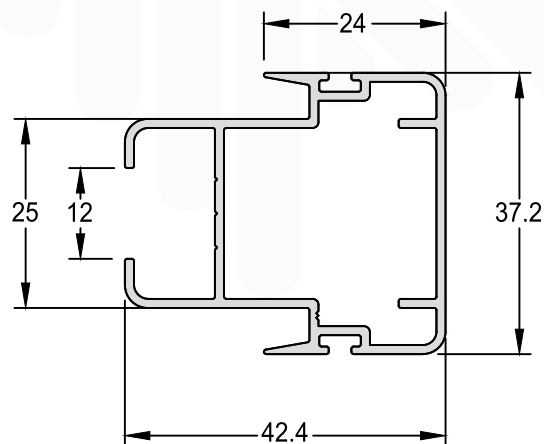

Folha Superior e Inferior
Horizontal - Veneziana

SU-187A 0,496 kg/m

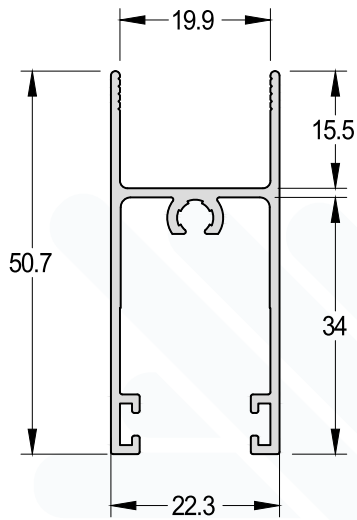

Folha Mão de Amigo Central
Veneziana

SU-069 0,592 kg/m

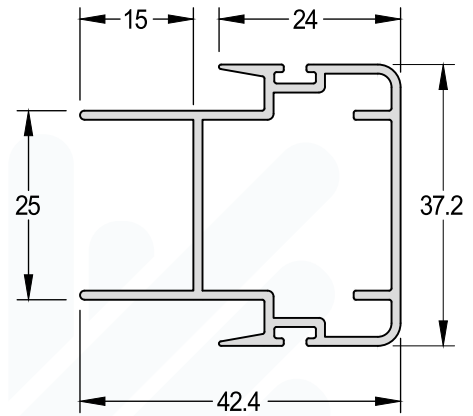

Quadro Mosquiteira

TM-171 0,217 kg/m

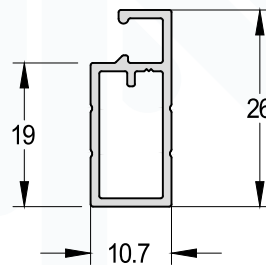

Marco Tubular - Maxim-ar	
SU-079	0,390 kg/m
Encaixe: SU-103A/ SU-103B/ SU-292	

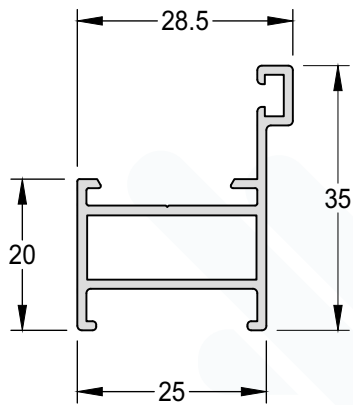
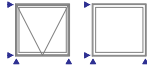

Coluna / Travessa	
SU-086	0,582 kg/m
Encaixe: SU-103A/ SU-102B/ SU-292	

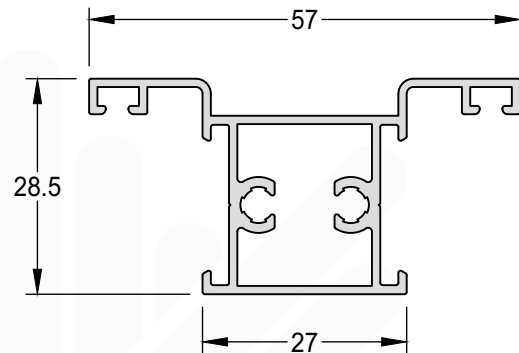
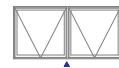

Inverso de Baguete	
SU-292	0,212 kg/m
Encaixe: SU-102A/ SU-102B/ SU-102C/ SU-108/ SU-079/ SU-086	

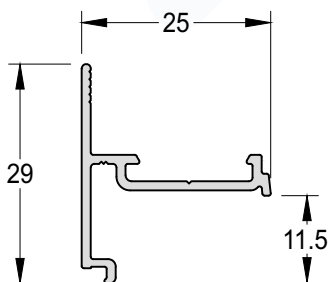

Pingadeira -Maxim-ar	
SU-083	0,150 kg/m
Encaixe: SU-079/ SU-086	

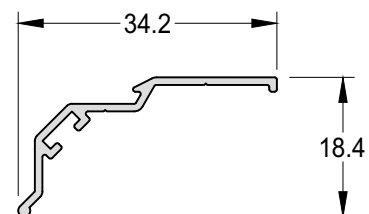

Folha Superior - Maxim-ar

SU-080 0,357 kg/m

Encaixe: SU-102A/ SU-102B/ SU-102C

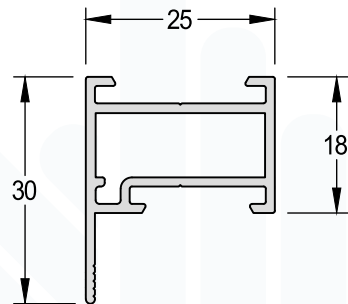

Folha Inf. e Lateral - Maxim-ar

SU-200 0,435 kg/m

Encaixe: SU-102A/ SU-102B/ SU-102C

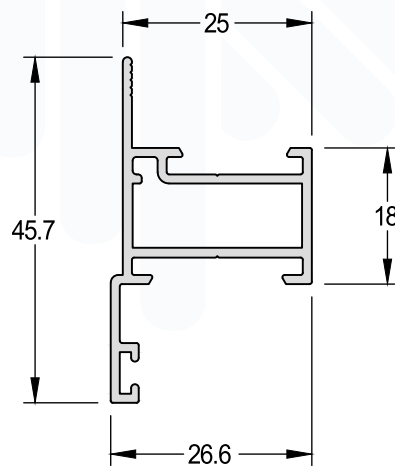

Marco Lateral
25-514 0,458 kg/m

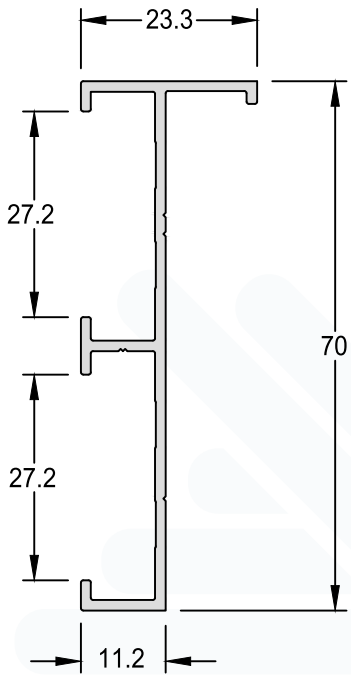
Marco Portinhola
25-002 0,349 kg/m

Marco Portinhola
SU-065 0,380 kg/m

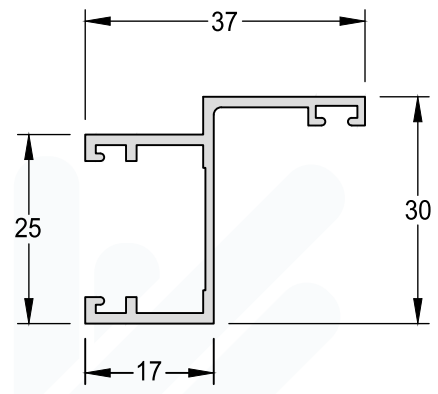
Complemento Marco
SU-071 0,268 kg/m

Folha Perimetral - Portinhola
SU-064 0,487 kg/m

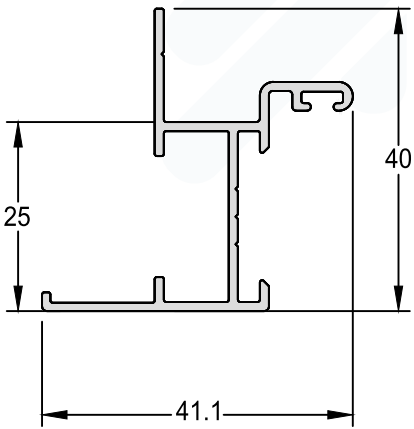

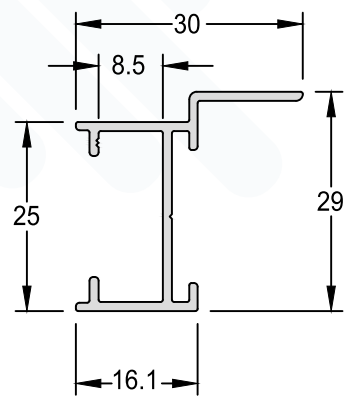
Folha Perimetral - Portinhola
25-016 0,417 kg/m
Encaixe: SU-102A/ SU-102B/ SU-102C/
SU-108/SU-203A

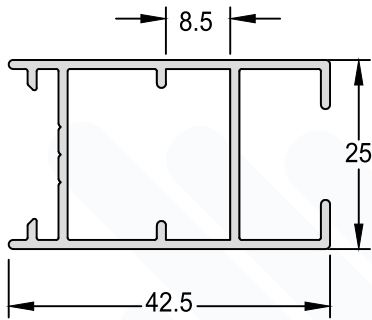

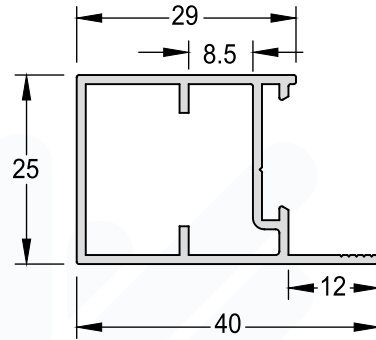
Folha Perimetral - Porta de Giro
25-542A 0,604 kg/m
Encaixe: BG-001

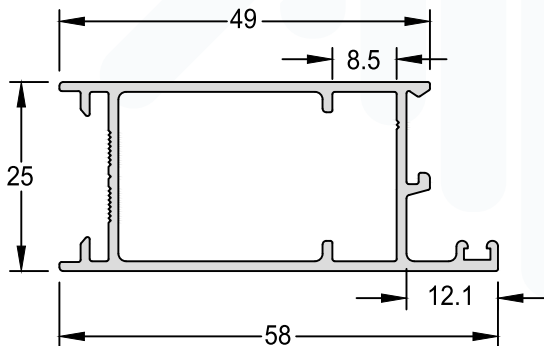

Baguete Vertical e Horizontal
BG-001 0,104 kg/m
Encaixe: 25-542A

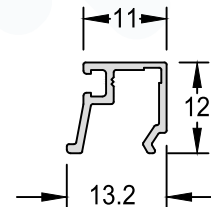

Marco Tubular - Porta de Giro
25-540 0,417 kg/m

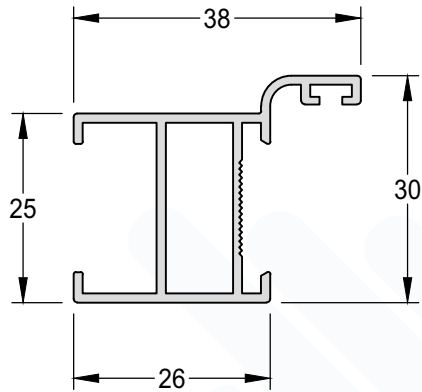

Coluna / Travessa

25-541 0,572 kg/m

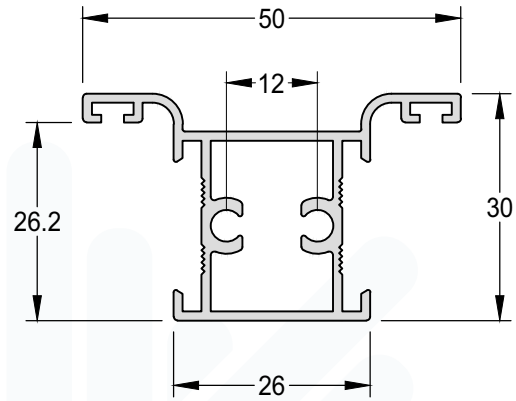

Batente - Porta de Giro
25-548 0,213 kg/m

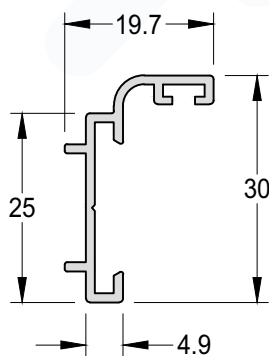

Folha Perimetral - Porta de Giro
SU-111 0,556 kg/m

Encaixe: SU-102A / SU-102B /
SU-102C / SU-108 / SU-203A

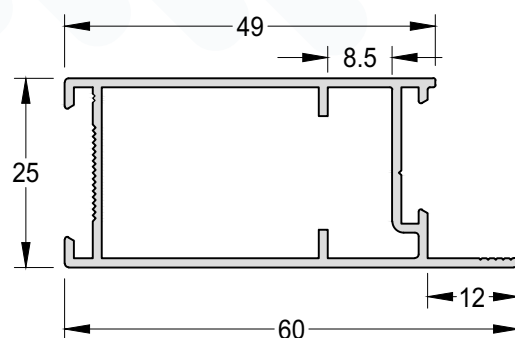

Baguete Vertical e Horizontal

SU-102A 0,109 kg/m

Encaixe: SU-039A/ SU-245A/ SU-040A/
SU-041A/ SU-038A/ SU-243A/
SU-242A/ SU-238A/ SU-225/
SU-227/ SU-053/ SU-246A

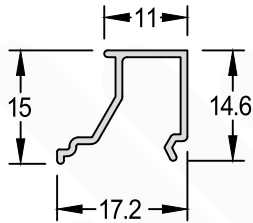
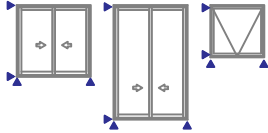

Baguete Vertical

SU-102B 0,103 kg/m

Encaixe: SU-039A/ SU-245A/ SU-040A/
SU-041A/ SU-038A/ SU-243A/ SU-242A/
SU-238A

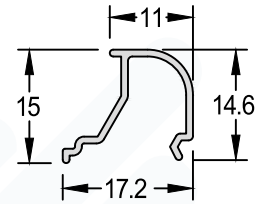
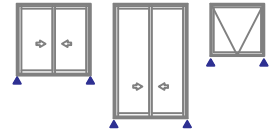

Baguete Vertical e Horizontal

SU-102C 0,106 kg/m

Encaixe: SU-039A/ SU-245A/ SU-040A/
SU-041A/ SU-038A/ SU-243A/ SU-242A/
SU-238A/ SU-225/ SU-227/ SU-053/
SU-246A

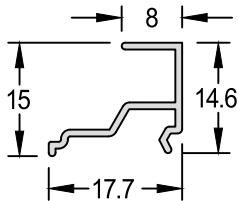
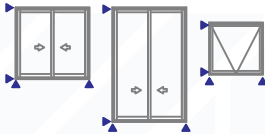

Baguete Terminal - Veneziana

SU-203 0,130 kg/m

Encaixe: SU-053/ SU-246A/ SU-225/
SU-227

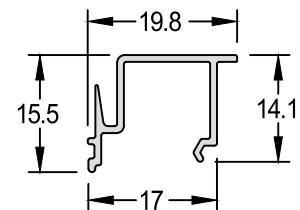

SISTEMA DE ESQUADRIAS LAGUNA 25

REV05

Complemento - Veneziana

SU-203A 0,089 kg/m

Encaixe: SU-039A/ SU-245A/ SU-040A/
SU-041A/ SU-038A/ SU-243A/ SU-242A/
SU-238A/ SU-225/ SU-227/ SU-053/
SU-246A/ SU-111/ 25-016

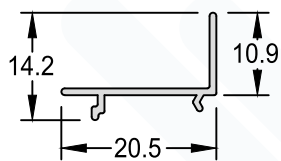

Complemento - Veneziana

SU-108 0,130 kg/m

Encaixe: SU-039A/ SU-245A/ SU-040A/
SU-041A/ SU-038A/ SU-243A/ SU-242A/
SU-238A/ SU-111/ 25-016

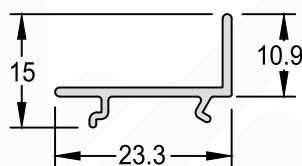

Baguete do Marco Maxim-ar

SU-103A 0,125 kg/m

Encaixe: SU-079/ SU-086

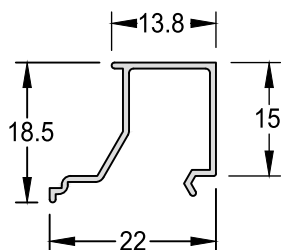

Baguete do Marco Maxim-ar

SU-103B 0,124 kg/m

Encaixe: SU-079/ SU-086

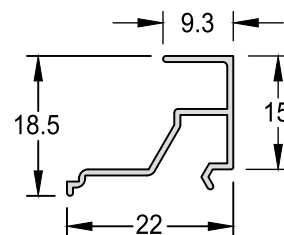
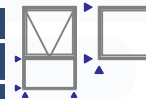

Veneziana Baixa - Cega

VZ-024 0,268 kg/m

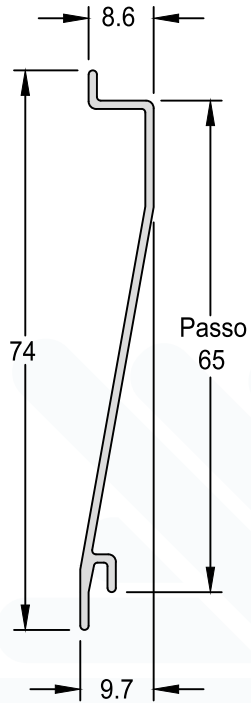

Veneziana Baixa - Ventilada

VZ-024F 0,268 kg/m

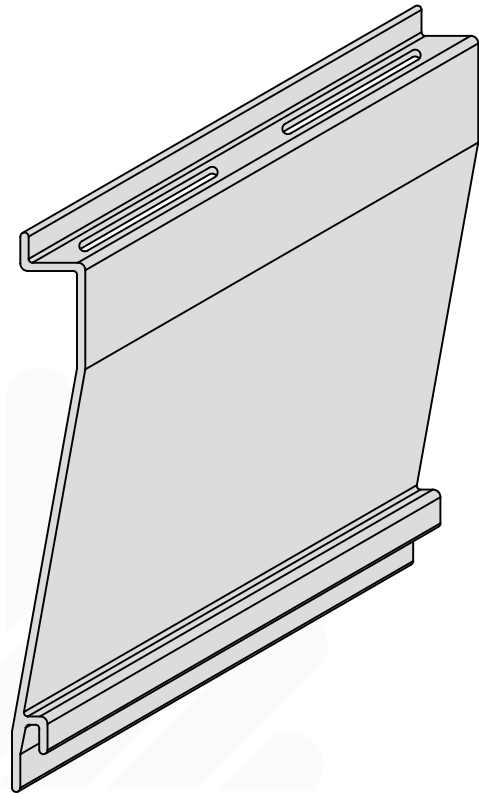

Veneziana - Cega

VZ-051 0,265 kg/m

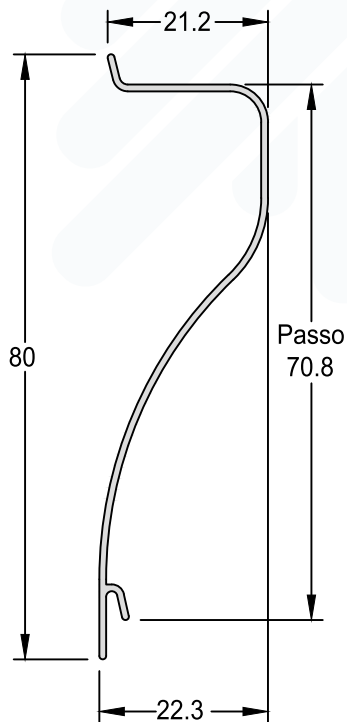

Veneziana - Ventilada

VZ-051F 0,265 kg/m

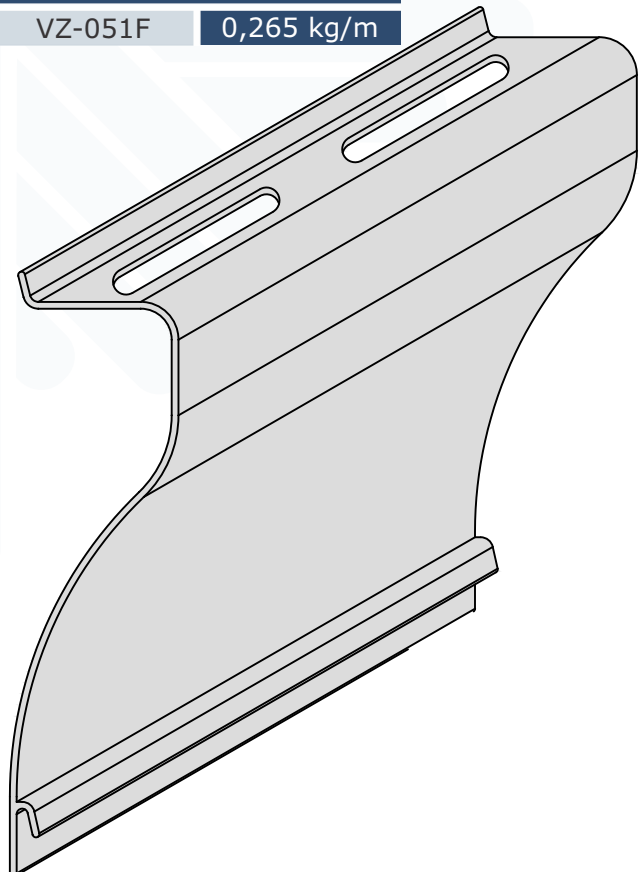

Veneziana - Cega

VZ-106 0,403 kg/m

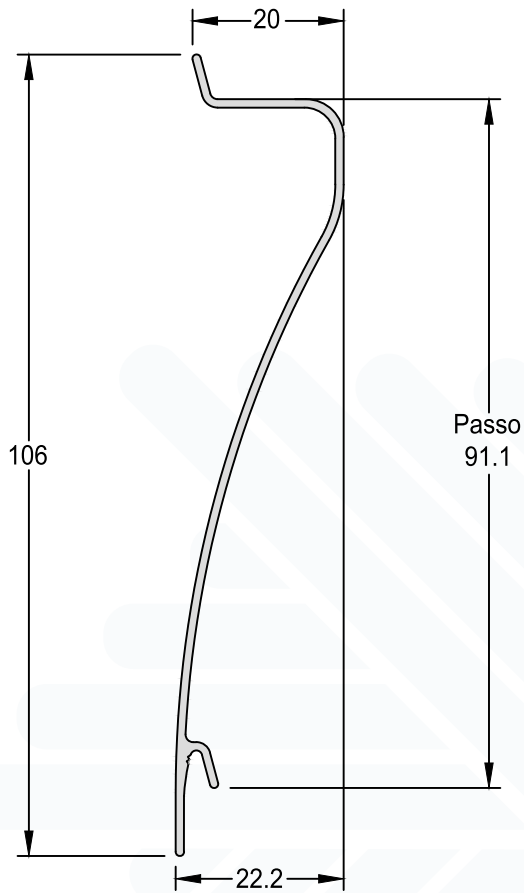

Veneziana - Ventilada

VZ-106F 0,403 kg/m

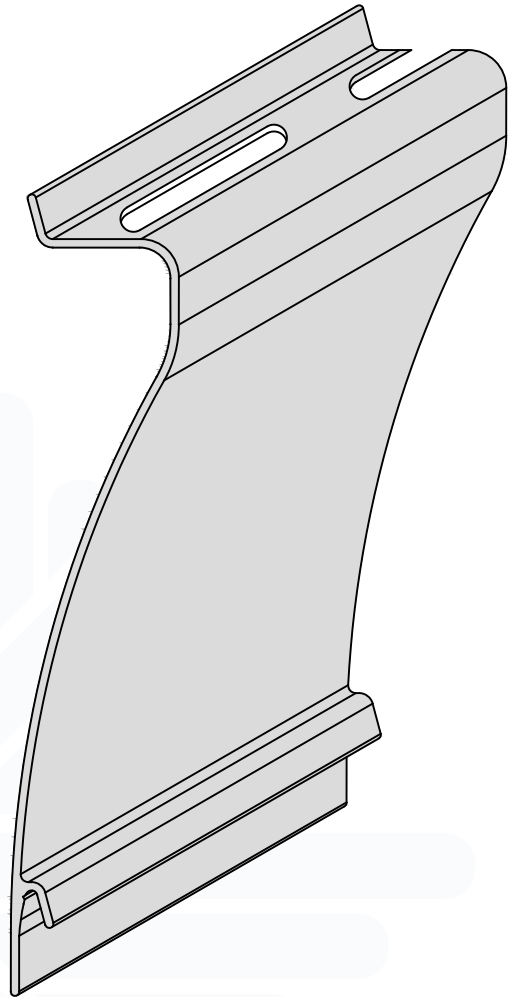

Veneziana - Ventilação Permanente

LG-037 0,513 kg/m

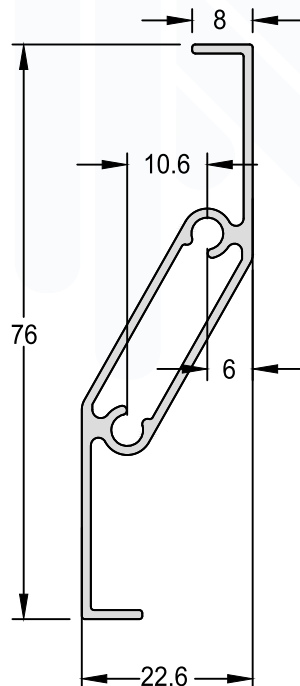

Lambri Liso

LB-035	0,706 kg/m
Medida Padrão	5000mm/6000mm

Lambri Frisado

LB-050	0,628 kg/m
--------	------------

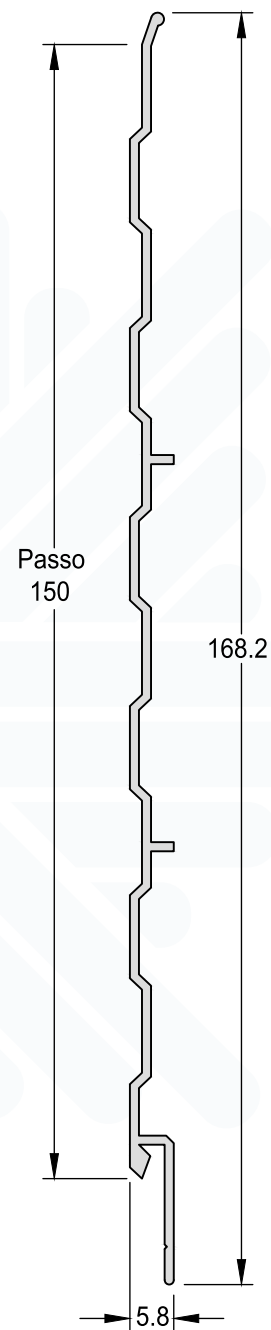
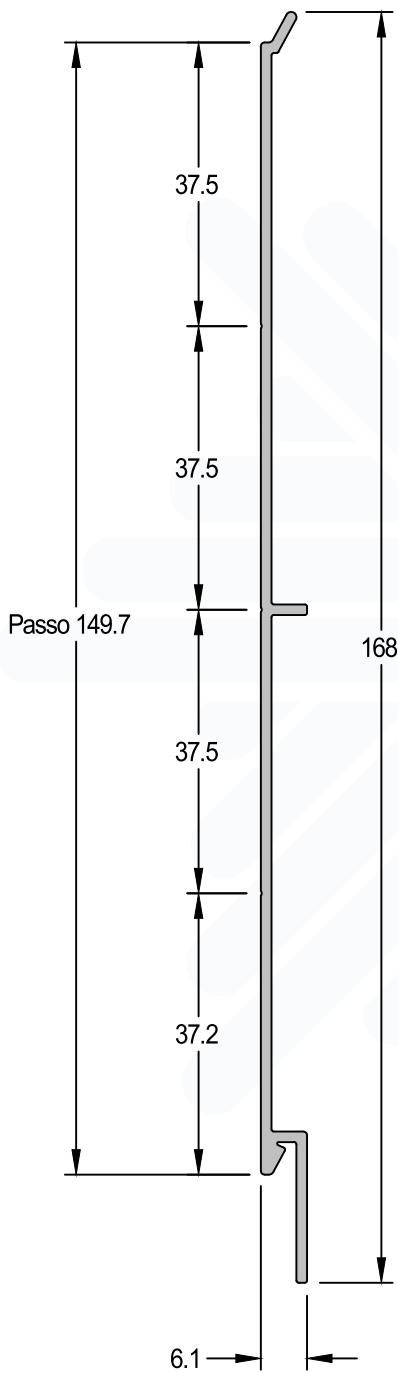

SISTEMA DE ESQUADRIAS LAGUNA 25
 REV05

Lambri Duplo - Liso

LB-061

0,691 kg/m

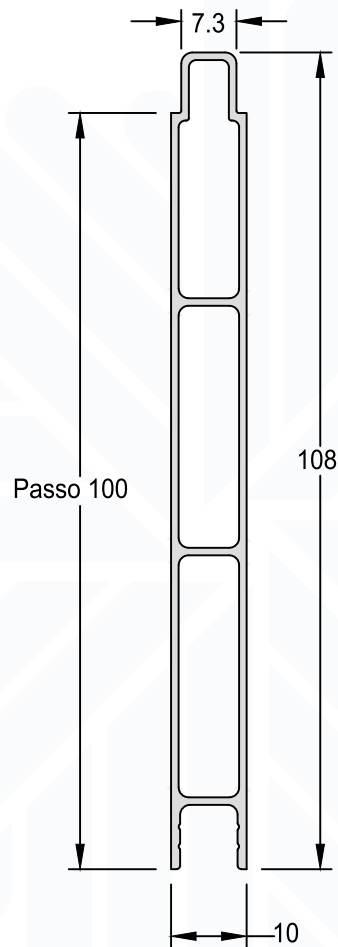

ÍNDICE DE COMPONENTES

Código	Descrição	Página
SD-2506	Vedação Superior	54
CAL-948	Calço da Folha Fixa	54
SD-2507	Caixa de Dreno	54
MAX-VED	Caixa de Dreno	54
GUI-005	Guia Deslizante	55
VED210	Guia Deslizante	55
VED245	Guia Deslizante	55
VED280	Guia Deslizante	55
NYL-042	Tapa Furo	55
NYL-414	Batedeira	56
BAT-UNI	Batedeira Universal	56
NYL-190	Persilha de Fixação do Arremate	56
TPA-2591	Tampa do Montante	56
SD-2581	Roldana 20 Kgs	57
FIT REG/PH	Roldana 40 Kgs	57
SD-2578	Roldana 40 Kgs	57
UDIPLUS - 25	Roldana 50 Kgs	57
CON-7411	Fecho Concha	58
CON-2011	Fecho Concha	58
CON-7311	Concha Cega	59
CON-7811AC	Fecho Concha com Chave	59
CON-7811	Fecho Concha	60
CON-7711	Concha Cega	60
SD-2504	Contra Fecho	61
FEC-055	Contra Fecho - Folha Fixa	61
CON-409	Concha Fecho	61
CON-TOUCH	Concha Fecho Touch	61
FRA-815A	Fechadura - Correr	62
SD-2586	Click de Nylon P/Marco Inferior	63
LINCON-337000	Lingueta Para Fecho Concha	63
LIN-7611	Lingueta Fecho Touch	63
BRA-(Ver Tabela)	Braço Maxim-ar	64
FEC-009	Fecho Maxim-ar	65
FEC-010	Fecho Maxim-ar	65
FRA-323	Fechadura	66
CON-295	Contra Testa	66
MAC-EURO	Maçaneta Roseta	67
MAC-EURO	Maçaneta Roseta	67
DOB-840	Dobradiça 2 Abas	68
DOB-840	Dobradiça 3 Abas	68
FEC-1920CF	Fecho Unha	68
VEDPORIN	Vedação Inferior Porta	69
PAR-437	Parafuso AA Ø3,5 X9,5	70
PAR-936	Parafuso AA Ø4,2 X16	70
PAR-963	Parafuso AA Ø4,2 X25	70
PAR-694	Parafuso AA Ø4,2 X32	70
PAR-428	Parafuso PG Ø4,8 X38	71
PAR-431	Parafuso PG Ø4,8 X50	71
REB-440	Rebite Ø3,2 X10,2	71
REB-540	Rebite Ø4,0 X10,2	71
FIT-206	Escova 5x6	72
FIT-212	Escova 5x8	72
GUA-172	Espuma Adesiva	73
GUA-171	Espuma Adesiva	73
GUA-258	Espuma Adesiva	73
GUA-157	Espuma Adesiva	73
GUA-282	Espuma Adesiva	74
GUA-053	Guarnição EPDM	74
GUA-007	Guarnição EPDM	74
GUA-239	Guarnição EPDM	74
GUA-256	Guarnição EPDM	75
GUA-259	Guarnição EPDM	75
GUA-006	Guarnição EPDM	75

Vedação Superior

SD-2506

Encaixe: SU-001/ SU-005/ SU-010/
SU-121

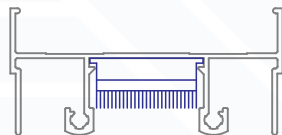
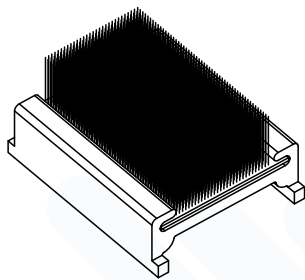

Calço da Folha Fixa

CAL-948

Encaixe: SU-053/ SU-246A/ SU-225/
SU-226/ SU-186/ SU-187A

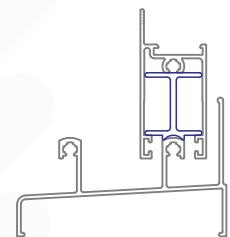
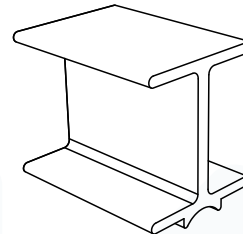

Caixa de Dreno

SD-2507

Encaixe: SU-002/ SU-006/ SU-011/
SU-022/ SU-228/ SU-230/ SU-2523/
SU-2541/ SU-111/ SU-2569/ SU-2621/
SU-2622/ SU-2522

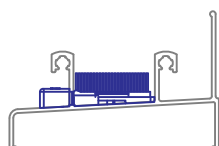
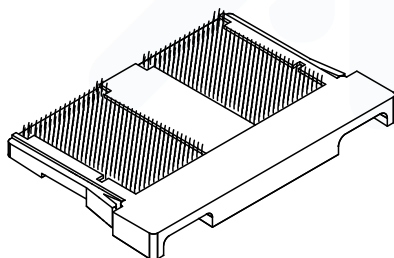

Caixa de Dreno

MAX-VED

Encaixe: SU-002/ SU-006/ SU-011/
SU-022/ SU-228/ SU-230/ SU-2523/
SU-2541/ SU-111/ SU-2569/ SU-2621/
SU-2622/ SU-2522

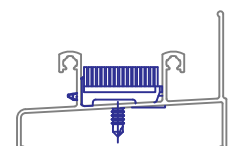
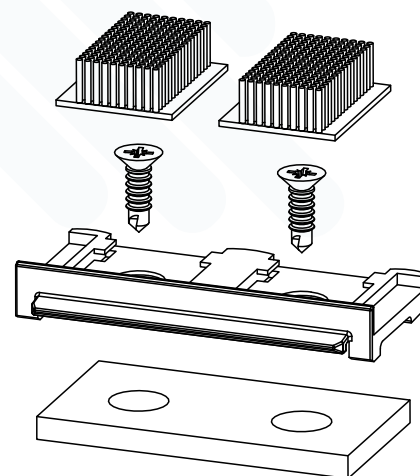

Guia Deslizante

GUI-005

Encaixe: SU-039/ SU-280/ SU-040/ SU-041/
SU-044/ SU-047/ SU-055/ SU-056/ SU-057/
SU-069/ SU-2586/ SU-2567/ SU-2590/
SU-2592/ SU-061

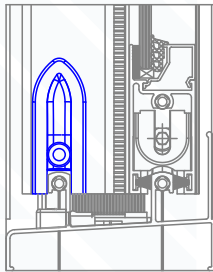
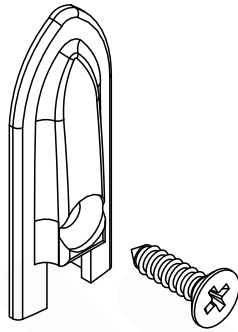

Guia Deslizante

VED210/ VED245/ VED280

Encaixe: SU-039/ SU-280/ SU-040/ SU-041/
SU-044/ SU-047/ SU-055/ SU-056/ SU-057/
SU-069/ SU-2586/ SU-2567/ SU-2590/
SU-2592/ SU-061

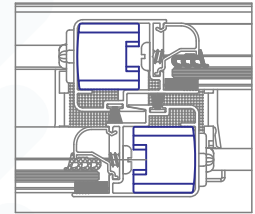
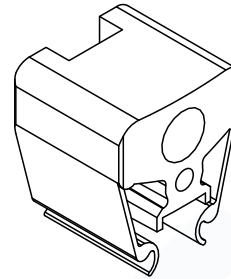

Tapa Furo

NYL-042

Encaixe: SU-039/ SU-280/ SU-040/ SU-041/
SU-044/ SU-047/ SU-055/ SU-056/ SU-057/
SU-069/ SU-2586/ SU-2567/ SU-2590/
SU-2592/ SU-061

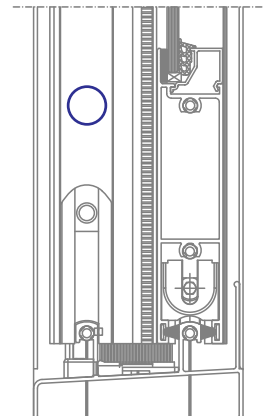
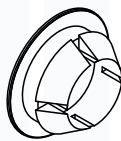

Batedeira
NYL-414
 Encaixe: SU-001/ SU-002/ SU-005/ SU-006
 SU-010/ SU-011/ SU-121/ SU-228/ SU-230
 SU-2523/ SU-2541/ SU-2542/ SU-2569/
 SU-2621/ SU-2622/ SU-2522/ SU-022

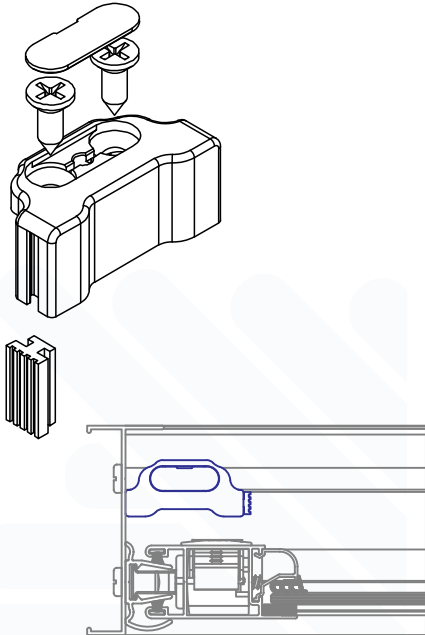

Batedeira Universal
BAT-UNI
 Encaixe: SU-053/ SU-246A/ SU-225/
 SU-226/ SU-186/ SU-187A

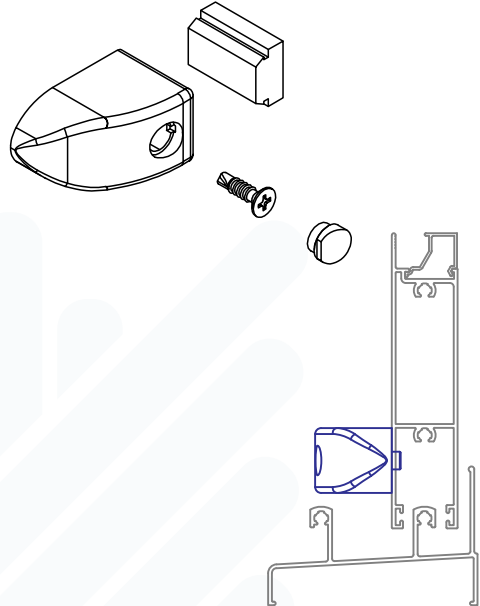

Persilha de Fixação do Arremate
NYL-190

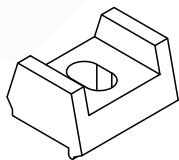

Tampa do Montante
TPA-2591
 Encaixe: SU-2586/ SU-044/ SU-047/
 SU-2592/ SU-061

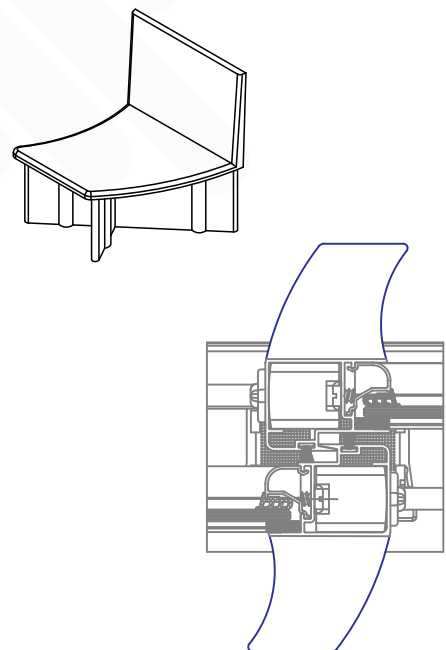

Detalhe de Aplicação Sem Escala

Roldana 20 Kgs

SD-2581

Encaixe: SU-053/ SU-246A/ SU-225/
SU-226/ SU-186/ SU-187A

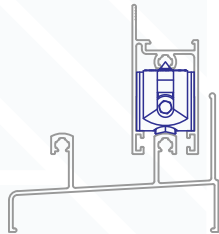
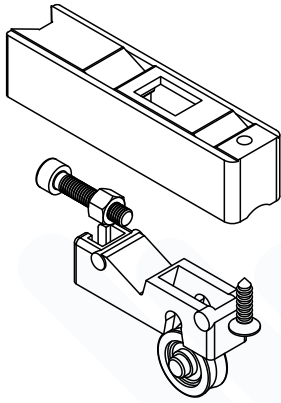

Detalhe de Aplicação
Sem Escala

Roldana 40 Kgs

FIT REG/PH

Encaixe: SU-053/ SU-246A/ SU-225/
SU-226/ SU-186/ SU-187A

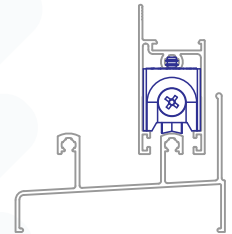
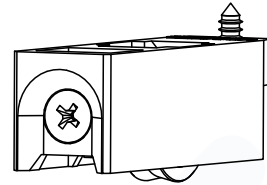

Detalhe de Aplicação
Sem Escala

Roldana 40 Kgs

SD-2578

Encaixe: SU-053/ SU-246A/ SU-225/
SU-226/ SU-186/ SU-187A

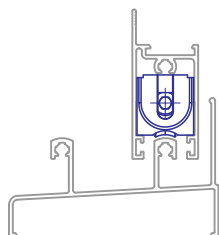
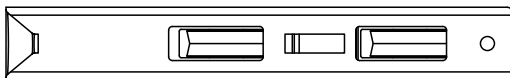

Detalhe de Aplicação
Sem Escala

Roldana 50 Kgs

UDIPLUS - 25

Encaixe: SU-053/ SU-246A/ SU-225/
SU-226/ SU-186/ SU-187A

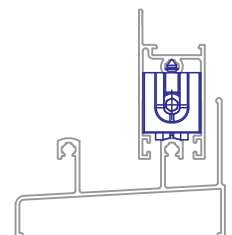
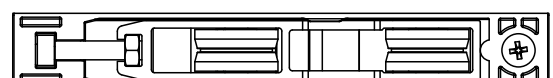

Detalhe de Aplicação
Sem Escala

Fecho Concha
CON-7411
 Encaixe: SU-039/ SU-280/ SU-055/
 SU-2586/ SU-2590/ SU-2592

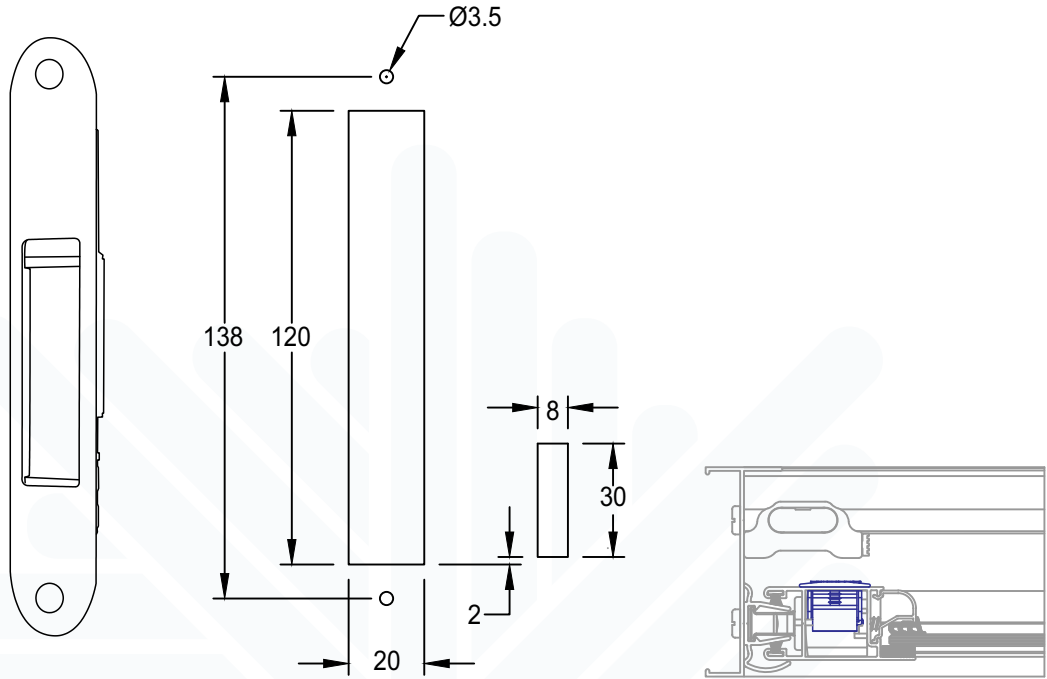

Medidas das usinagens conforme fabricante do componente.

Detalhe de Aplicação Sem Escala

Fecho Concha
CON-2011
 Encaixe: SU-039/ SU-280/ SU-055/
 SU-2586/ SU-2590/ SU-2592

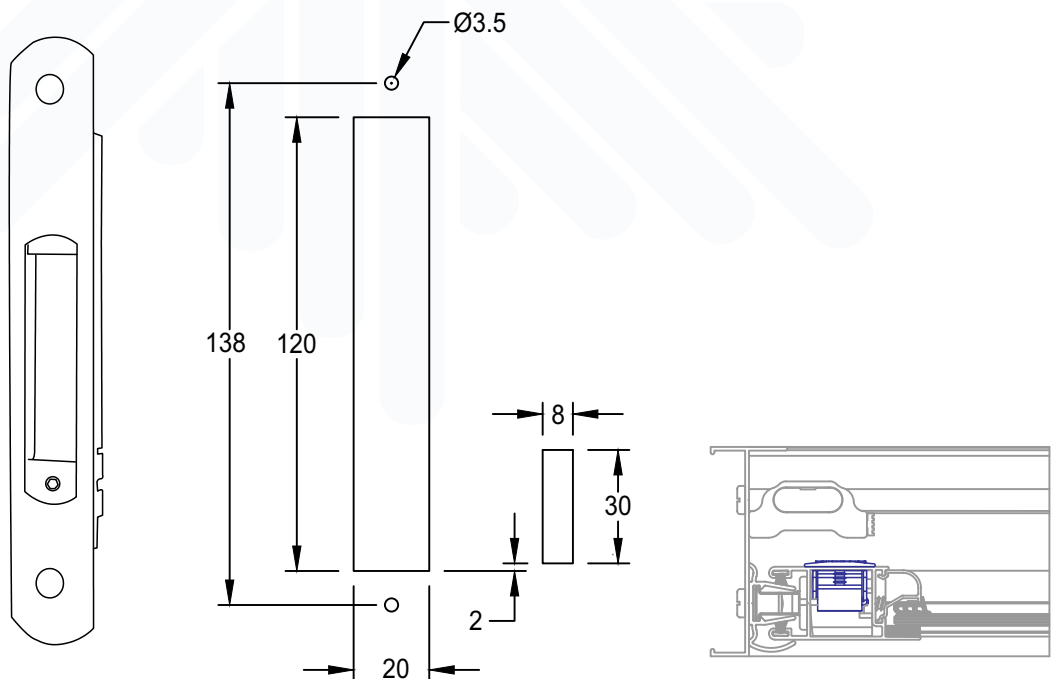

Medidas das usinagens conforme fabricante do componente.

Detalhe de Aplicação Sem Escala

Concha Cega

CON-7311

Encaixe: SU-039/ SU-280/ SU-055/
SU-2586/ SU-2590/ SU-2592

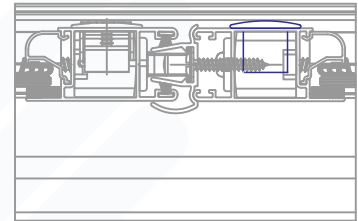
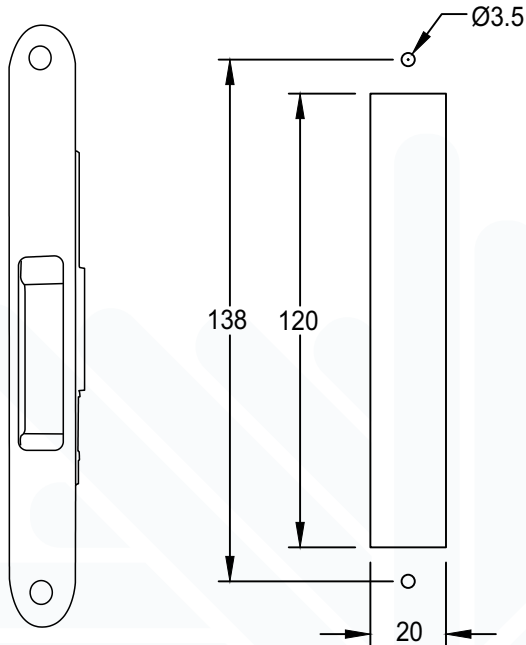
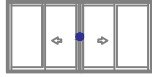

Medidas das usinagens conforme fabricante do componente.

Detalhe de Aplicação Sem Escala

Fecho Concha com Chave

CON-7811AC

Encaixe: SU-039/ SU-280/ SU-055/
SU-2586/ SU-2590/ SU-2592

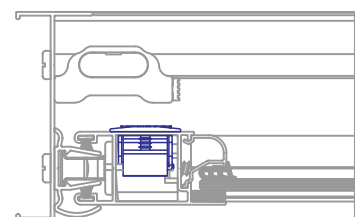
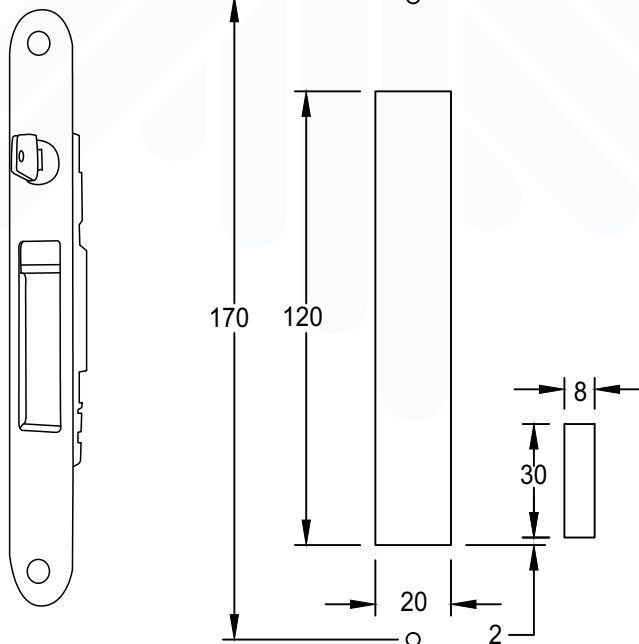

Medidas das usinagens conforme fabricante do componente.

Detalhe de Aplicação Sem Escala

Fecho Concha
CON-7811
 Encaixe: SU-039/ SU-280/ SU-055/
 SU-2586/ SU-2590/ SU-2592

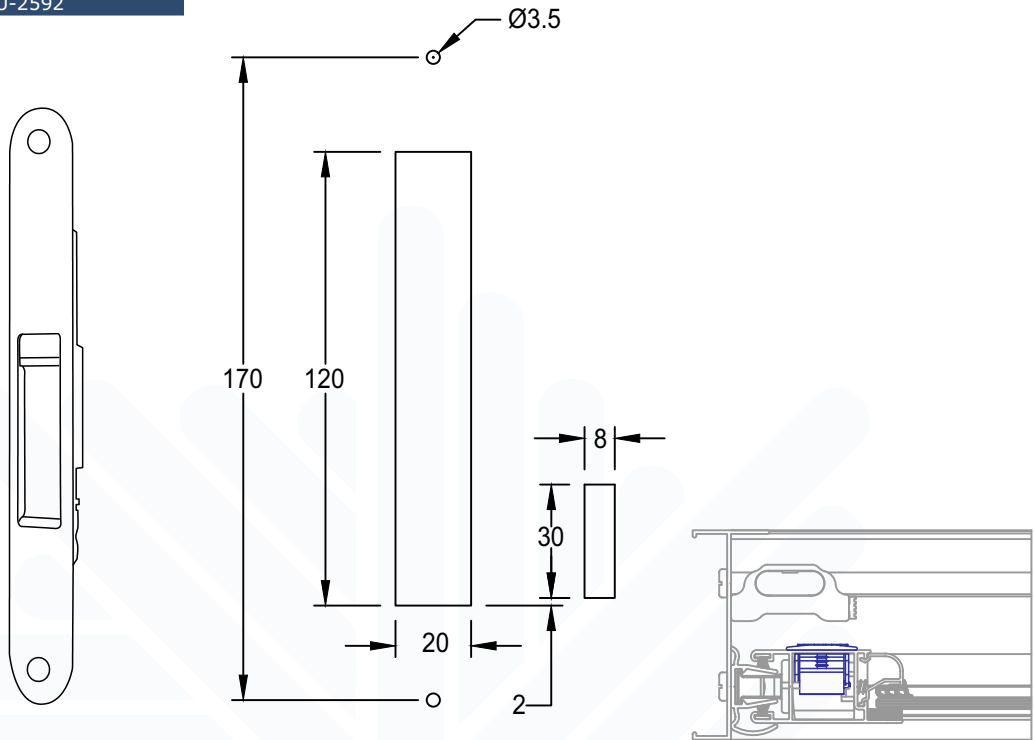

Medidas das usinagens conforme fabricante do componente.

Concha Cega
CON-7711
 Encaixe: SU-039/ SU-280/ SU-055/
 SU-2586/ SU-2590/ SU-2592

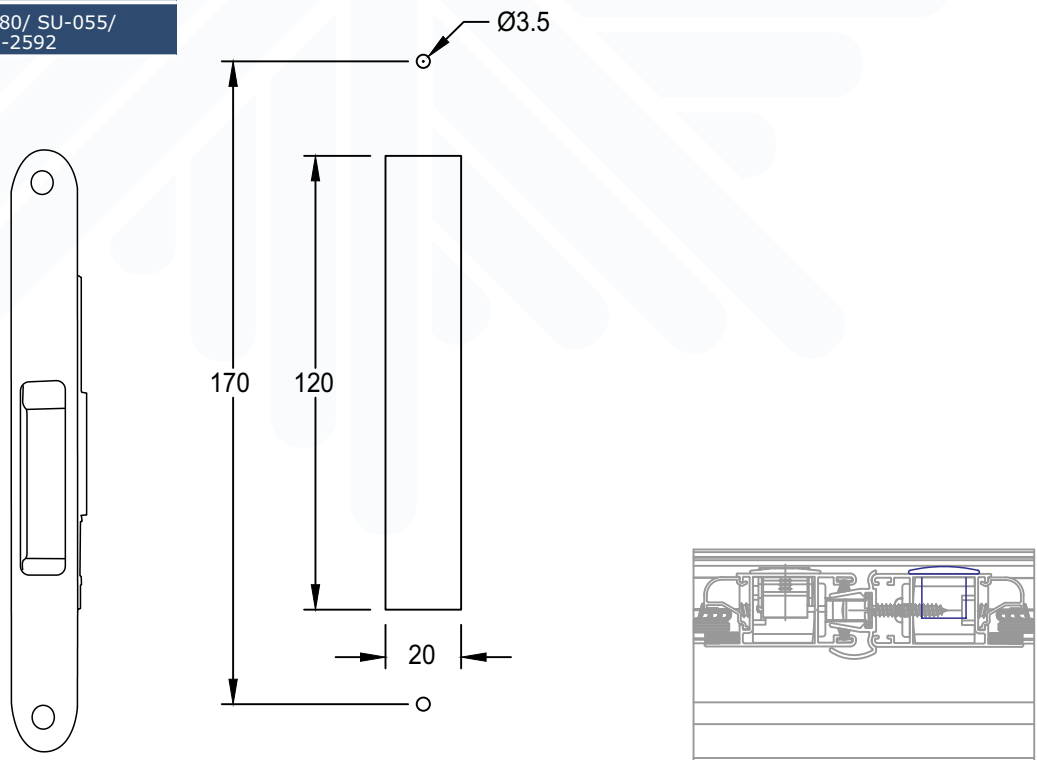

Medidas das usinagens conforme fabricante do componente.

Contra Fecho

SD-2504

Encaixe: SU-003/ SU-008/ SU-013/
SU-014

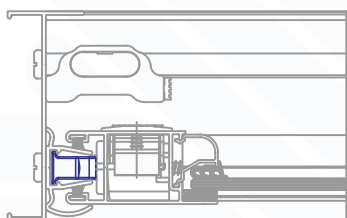
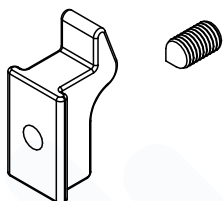

Contra Fecho - Folha Fixa

FEC-055

Encaixe: SU-039/ SU-280/ SU-055/
SU-2586/ SU-2590/ SU-2592

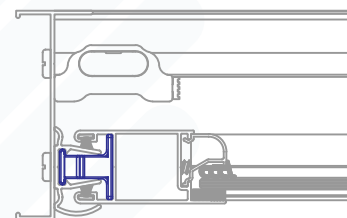
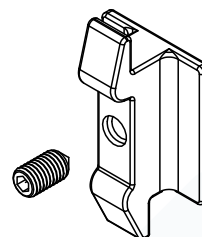

Concha Fecho

CON-409

Encaixe: SU-003/ SU-008/ SU-013/
SU-014

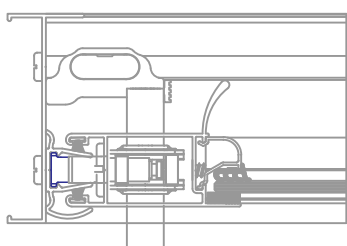
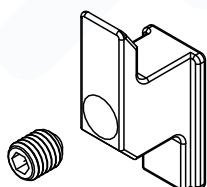

Concha Fecho Touch

CON-TOUCH

Encaixe: SU-003/ SU-008/ SU-013/
SU-014

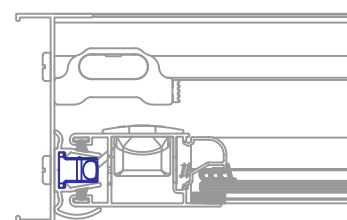
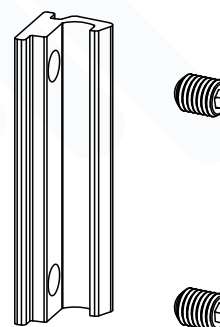

Fechadura - Correr

FRA-815A

Encaixe: SU-280/ SU-2586/ SU-2590/
SU-2592

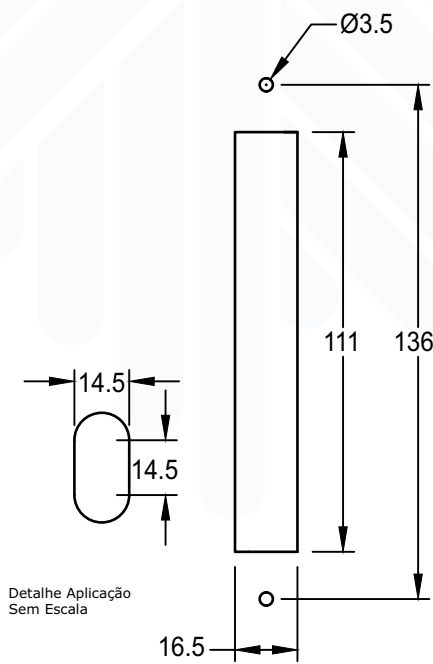
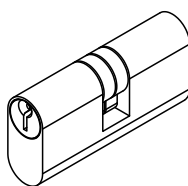
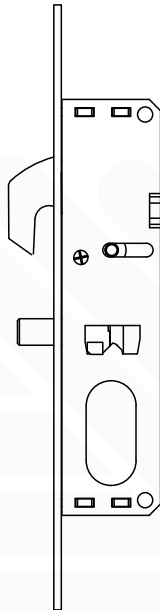

Detalhe Aplicação Sem Escala

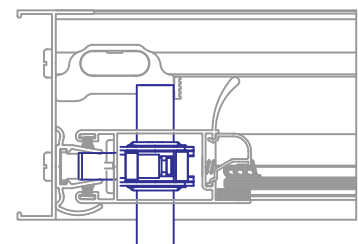

Medidas das usinagens conforme fabricante do componente.

Click de Nylon P/Marco Inferior

SD-2586

Encaixe: SU-2541/ SU-2523/ SU-2542/
SU-2621/ SU-2622/ SU-2569/ SU-2522

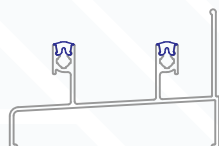
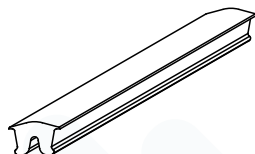

Lingueta Para Fecho Concha

LINCON-337000

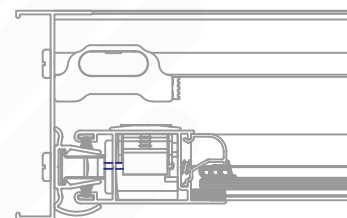
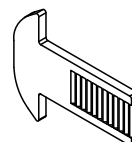

Lingueta Fecho Touch

LIN-7611

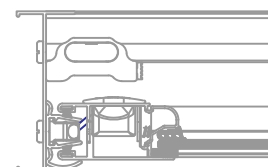
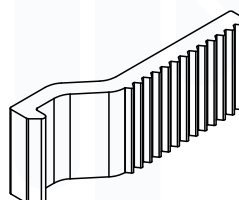

Detalhe de Aplicação
Sem Escala

Braço Maxim-ar
BRA-(Ver Tabela)

Encaixe: SU-079/ SU-086/ SU-200

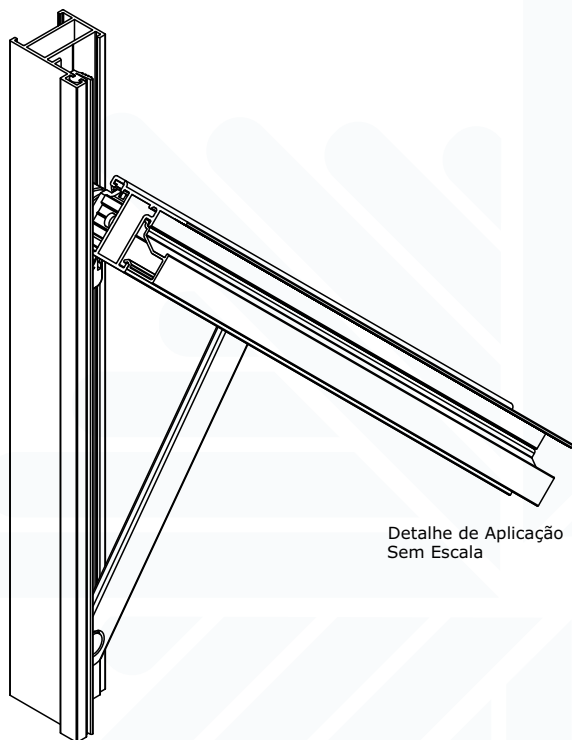
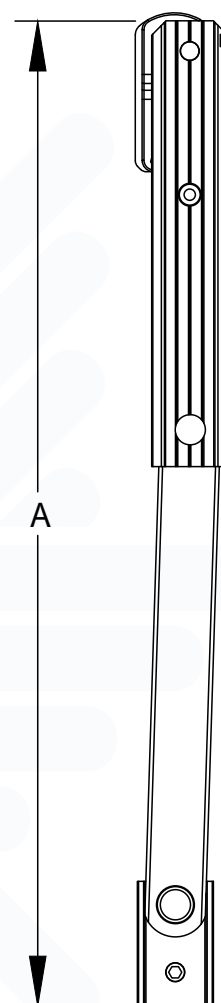

 Detalhe de Aplicação
 Sem Escala

CÓDIGO	DIMENSÃO	LARGURA	ALTURA DA FOLHA		CARGA
			MÁXIMA (MM)	MÍNIMA (MM)	
BRA-705	250	750	270	500	6
BRA-704	400	750	400	650	8
BRA-702	500	750	520	810	10
BRA-703	750	750	810	900	11
BRA-725	810	750	900	1200	15

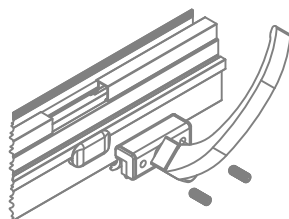
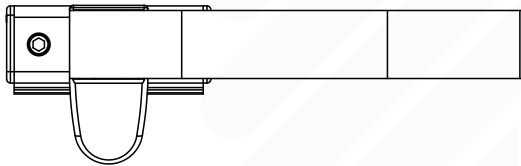
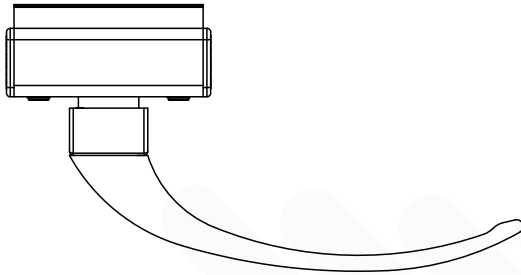
Fecho Maxim-ar
FEC-009

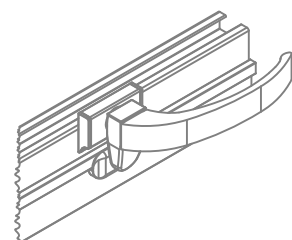
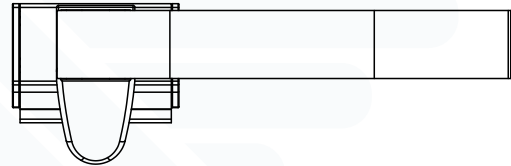
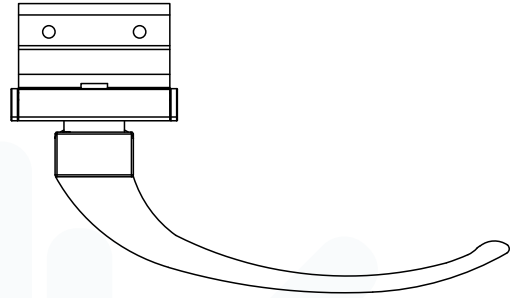

Fecho Maxim-ar
FEC-010



Detalhe de Aplicação
Sem Escala

Fechadura
FRA-323
Encaixe: SU-111/ 25-542A



Contra Testa
CON-295
Encaixe: 25-540/ 25-541/ 25-548

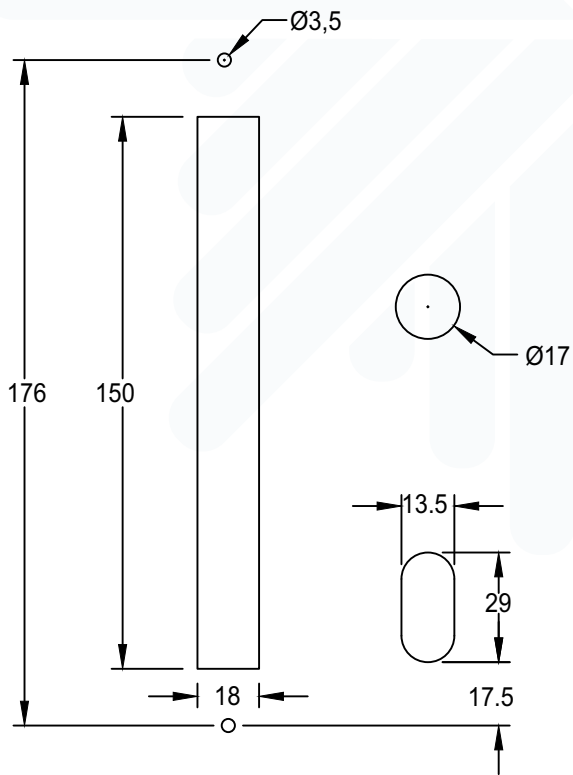
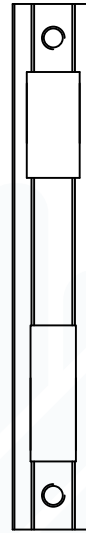
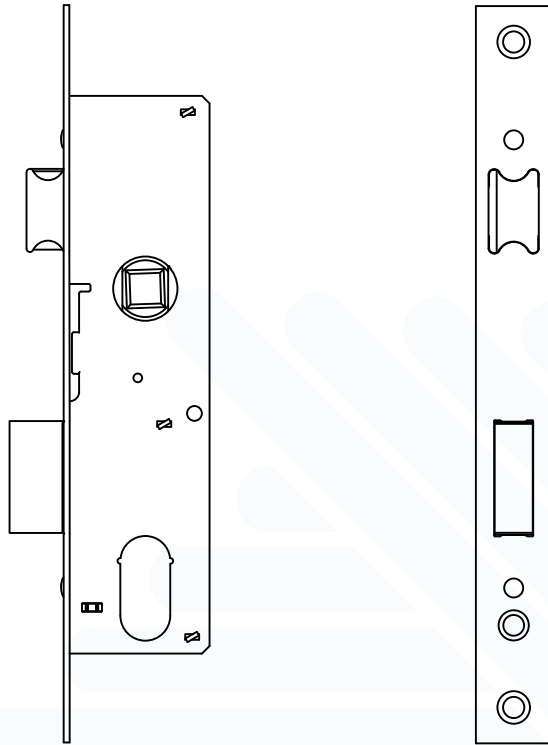

Detalhe Aplicação
Sem Escala

Medidas das usinagens conforme fabricante do componente.

Maçaneta Roseta

MAC-EURO

Encaixe: SU-111/ 25-542A

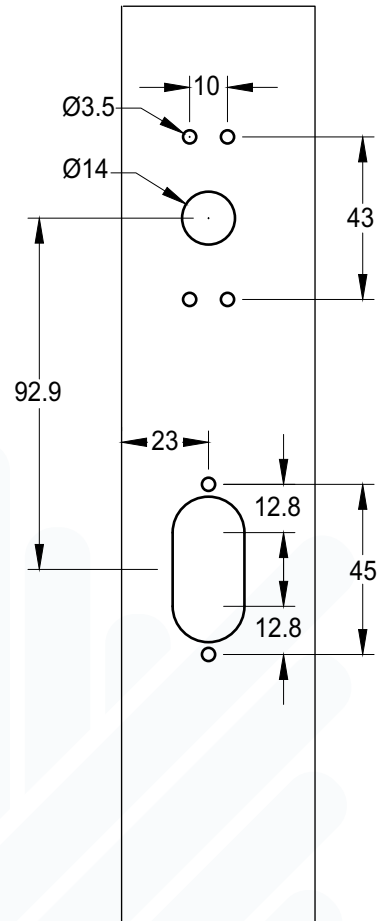
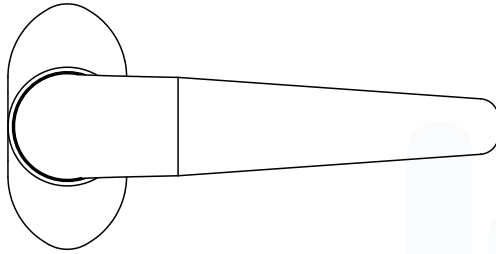

Medidas das usinagens conforme fabricante do componente.

Maçaneta Roseta

MAC-EURO

Encaixe: SU-111/ 25-542A

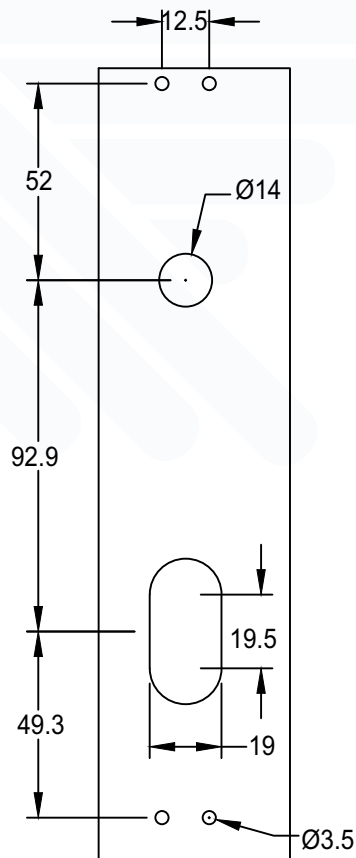
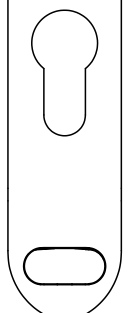
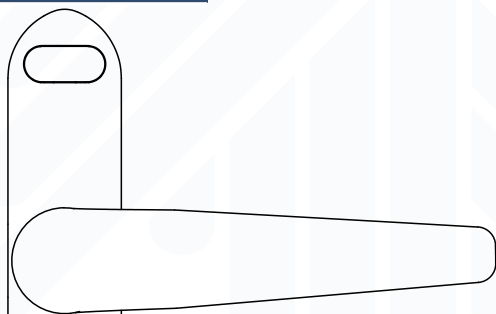

Medidas das usinagens conforme fabricante do componente.

Dobradiça 2 Abas
DOB-840
 Encaixe: SU-065/ SU-064/ 25-540/
 25-541/ 25-542A/ SU-111

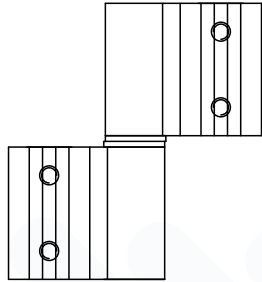
Dobradiça 3 Abas
DOB-840
 Encaixe: SU-065/ SU-064/ 25-540/
 25-541/ 25-542A/ SU-111

Fecho Unha
FEC-1920CF
 Encaixe: SU-111/ 25-542A

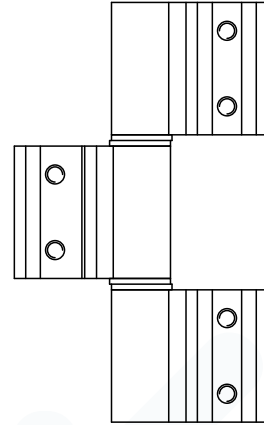
Contra Fechos

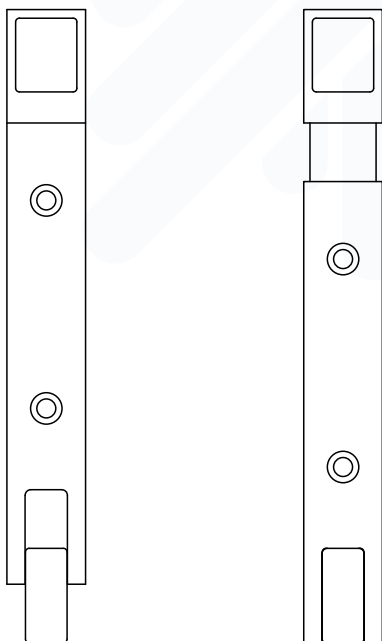

Vedação Inferior Porta

VEDPORIN

Encaixe: SU-111/ 25-542A



VERSÕES

620

720

820

920

1020

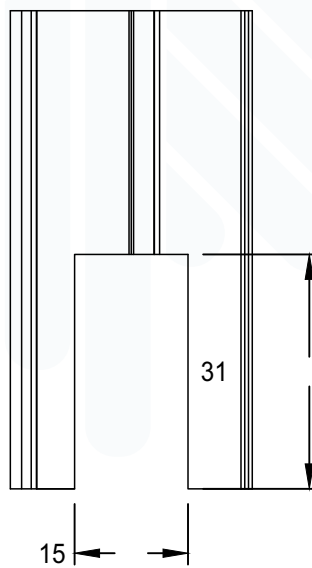
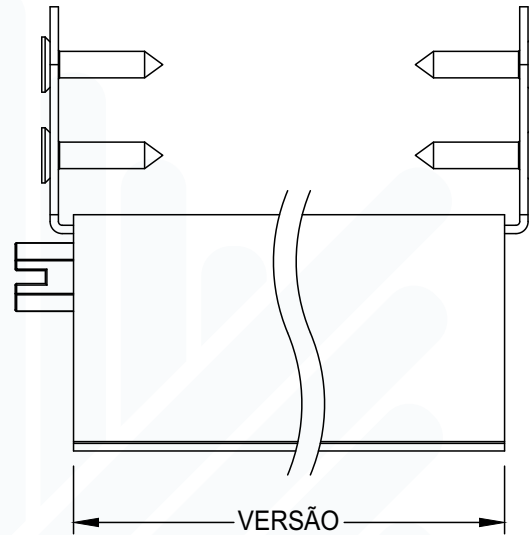
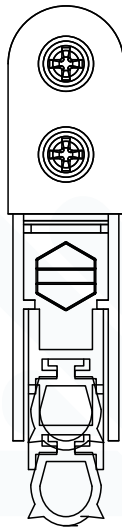

Medidas das usinagens conforme fabricante do componente.

Parafuso AA Ø3,5 X9,5

PAR-437

Uso: Fixação Mata Junta Lateral



Parafuso AA Ø4,2 X16

PAR-936

Uso: Fixação Presilha do Arremate



Parafuso AA Ø4,2 X25

PAR-963

Uso: Fixação Marco Maxim-ar

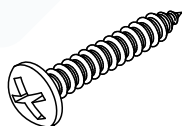

Parafuso AA Ø4,2 X32

PAR-694

Uso: Fixação Marco Porta de Giro

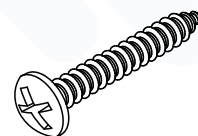

Parafuso PG Ø4,8 X38

PAR-428

Uso: Fixação Marco

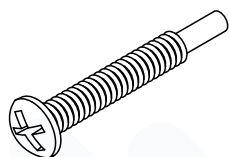

Parafuso PG Ø4,8 X50

PAR-431

Uso: Fixação Folhas

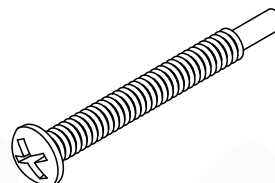

Rebite Ø3,2 X10,2

REB-440

Uso: Fixação Pingadeira Maxim-ar

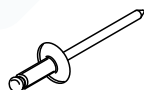

Rebite Ø4,0 X10,2

REB-540

Uso: Fixação Pingadeira Maxim-ar

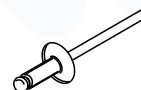

Escova 5x6

FIT-206

Uso: Folha Mão de Amigo e Lateral

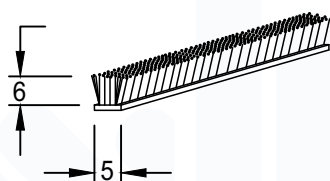

Escova 5x8

FIT-212

Uso: Folha Inferior e Superior Horizontal

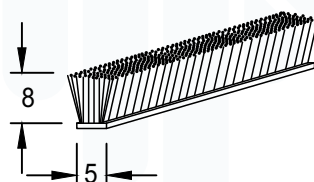

Espuma Adesiva

GUA-172

Uso: Vidros

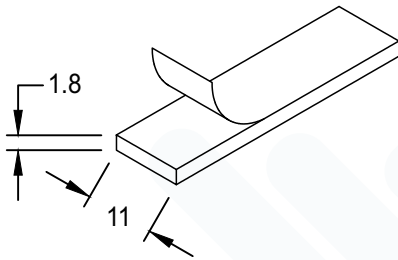

Espuma Adesiva

GUA-171

Uso: Vidros

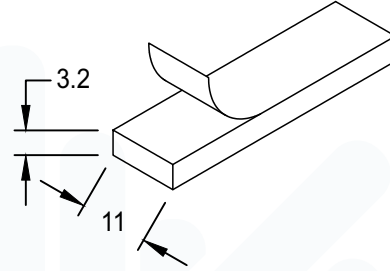

Espuma Adesiva

GUA-258

Uso: Vidros

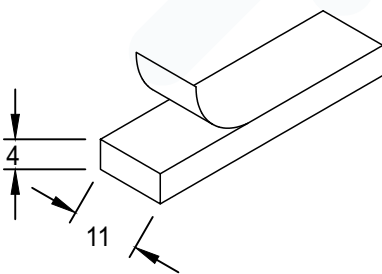

Espuma Adesiva

GUA-157

Uso: Vidros

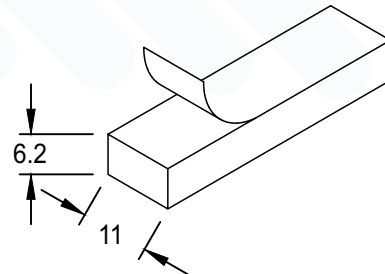

Espuma Adesiva
GUA-282
Uso: Vidros

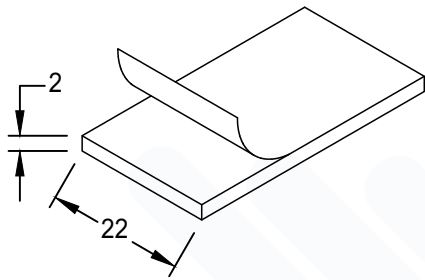

Guarnição EPDM
GUA-053
Uso: SU-200

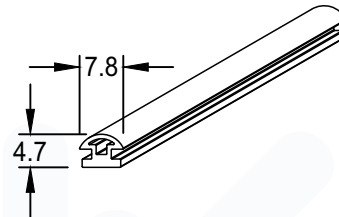

Guarnição EPDM
GUA-007
Uso: SU-083

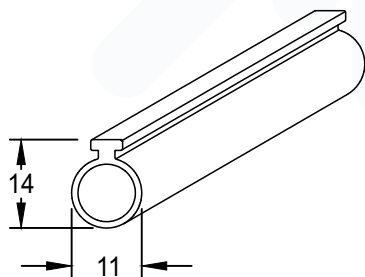

Guarnição EPDM
GUA-239
Uso: SU-079/ SU-086

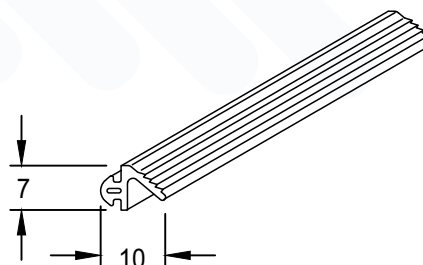

Guarnição EPDM

GUA-256

Uso: Vidros

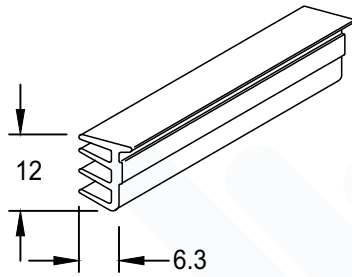

Guarnição EPDM

GUA-259

Uso: Vidros

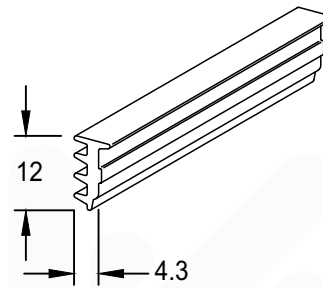

Guarnição EPDM

GUA-006

Uso: Integrada/ Tela Mosquiteira

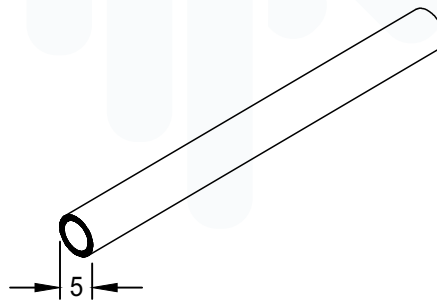

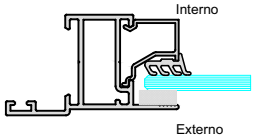
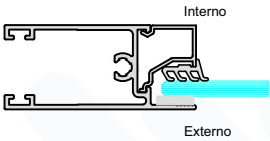
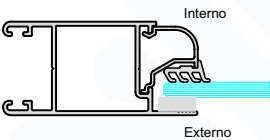
Detalhe De Aplicação	Espessura Do Vidro (mm)	Baguete	Guarnição Interna	Guarnição Externa
 <p>Folhas Maxim Ar</p>	4	SU-102A / SU102B	GUA-256	GUA-157
	5	SU-102A / SU102B	GUA-256	GUA-258
	6	SU-102A / SU102B	GUA-259	GUA-157
	8	SU-102C	GUA-259	GUA-258
 <p>Folhas Horizontais</p>	4	SU-102A / SU102B	GUA-256	GUA-157
	5	SU-102A / SU102B	GUA-256	GUA-171
	6	SU-102A / SU102B	GUA-259	GUA-171
	8	SU-102C	GUA-259	GUA-172
 <p>Folhas Verticais</p>	4	SU-102A / SU102B	GUA-256	GUA-157
	5	SU-102A / SU102B	GUA-256	GUA-258
	6	SU-102A / SU102B	GUA-259	GUA-258
	8	SU-102C	GUA-259	GUA-258

ÍNDICE DE USINAGENS

Código	Descrição	Página
SU-002	PERFIS	78
SU-003	PERFIS	80
SU-006	PERFIS	78
SU-007	PERFIS	81
SU-008	PERFIS	86
SU-011	PERFIS	79
SU-013	PERFIS	76
SU-014	PERFIS	75
SU-022	PERFIS	78
SU-039	PERFIS	84
SU-040	PERFIS	84
SU-041	PERFIS	84
SU-044	PERFIS	84
SU-044	PERFIS	85
SU-047	PERFIS	84
SU-047	PERFIS	85
SU-055	PERFIS	84
SU-056	PERFIS	84
SU-057	PERFIS	84
SU-061	PERFIS	84
SU-061	PERFIS	85
SU-069	PERFIS	84
SU-079	PERFIS	87
SU-080	PERFIS	88
SU-083	PERFIS	87
SU-086	PERFIS	87
SU-200	PERFIS	88
SU-228	PERFIS	78
SU-230	PERFIS	79
SU-2522	PERFIS	78
SU-2523	PERFIS	78
SU-2541	PERFIS	78
SU-2542	PERFIS	78
SU-2567	PERFIS	84
SU-2569	PERFIS	78
SU-2586	PERFIS	84
SU-2586	PERFIS	85
SU-2590	PERFIS	84
SU-2590	PERFIS	85
SU-2592	PERFIS	84
SU-2592	PERFIS	85
SU-2622	PERFIS	79
SU-280	PERFIS	84
SU-280	PERFIS	85

PERFIS

SU-002
 SU-2541
 SU-228
 SU-2523
 SU-006
 SU-2542
 SU-2569
 SU-2522
 SU-022

Usinagem De Dreno

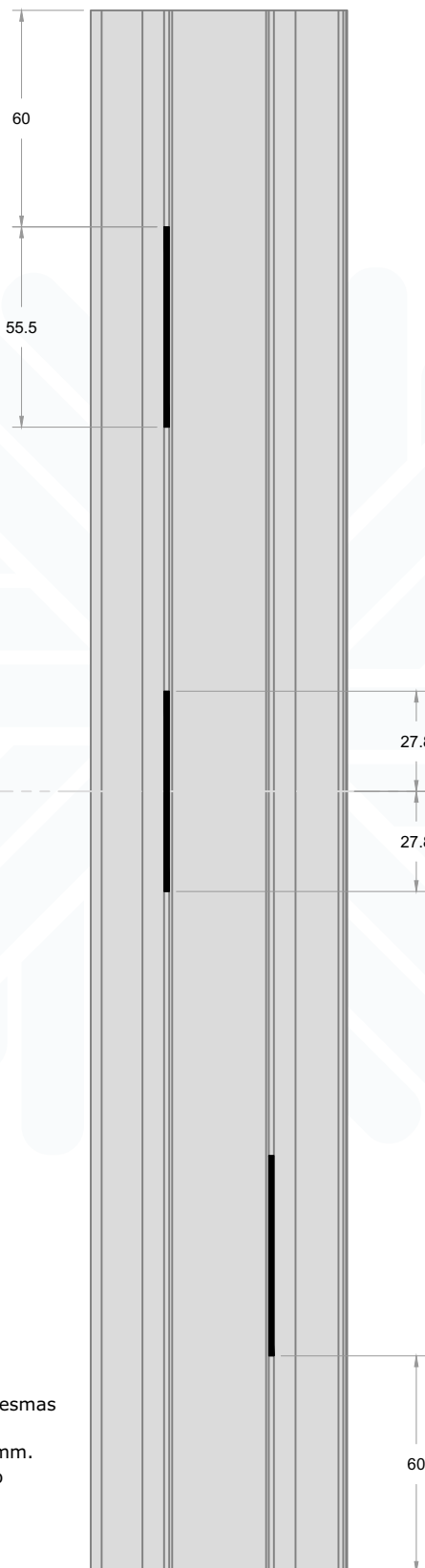
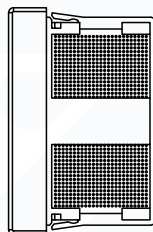
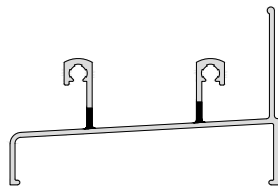
Observações:

- * Os drenos devem ser feitos sempre no sentido contrário da folha quando as mesmas estiverem fechadas.
- * Distância máxima entre os drenos 450mm.
- * Para vãos maiores, deve-se aumentar o número de drenos.

PERFIS

SU-011

SU-230

SU-2622

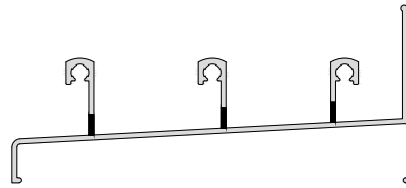

Usinagem De Dreno

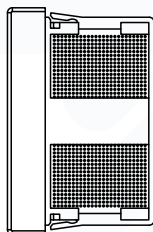
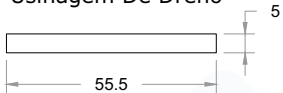

Observações:

- * Os drenos devem ser feitos sempre no sentido contrário da folha quando as mesmas estiverem fechadas.
- * Distância máxima entre os drenos 450mm.
- * Para vãos maiores, deve-se aumentar o número de drenos.

60

PERFIS
SU-003

Observações:

* Furações dos trilhos inferiores conforme perfil utilizado.

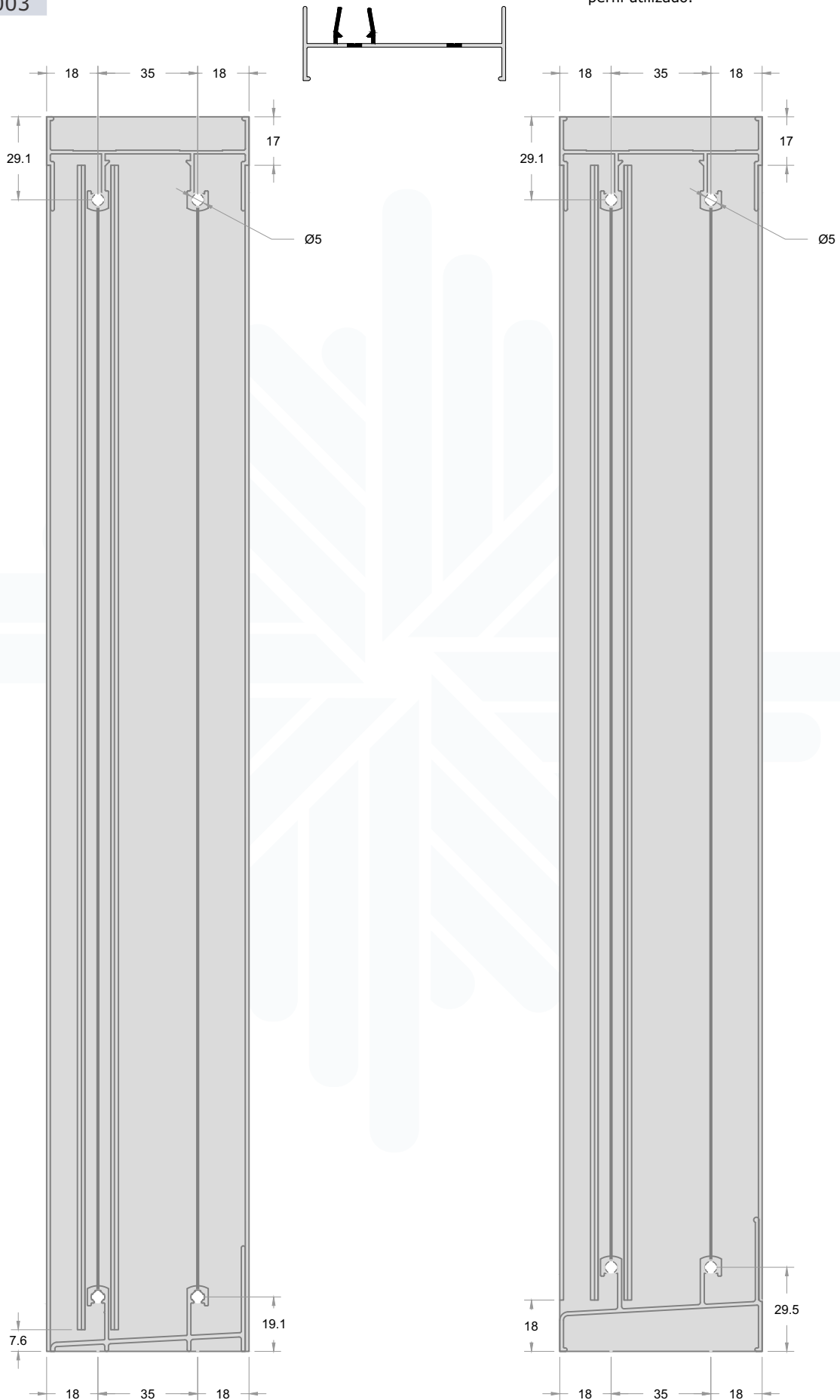

SISTEMA DE ESQUADRIAS **LAGUNA 25**
REV05

PERFIS
SU-007

Observações:

- * Furações dos trilhos inferiores conforme perfil utilizado.
- * Atentar-se a furação da travessa da bandeira.

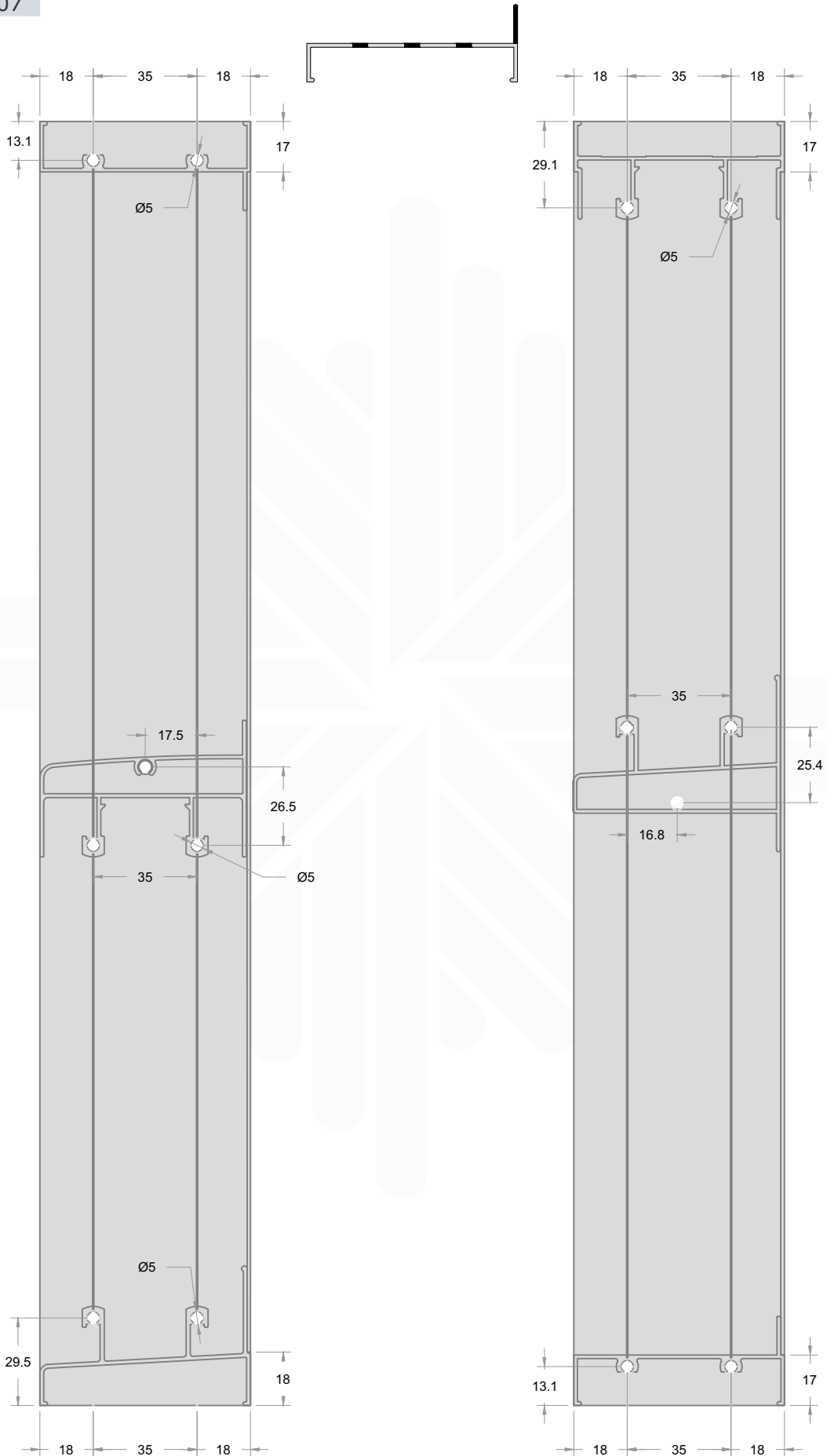

SISTEMA DE ESQUADRIAS LAGUNA 25
REV05

PERFIS
SU-014

Observações:

* Furações dos trilhos inferiores conforme perfil utilizado.

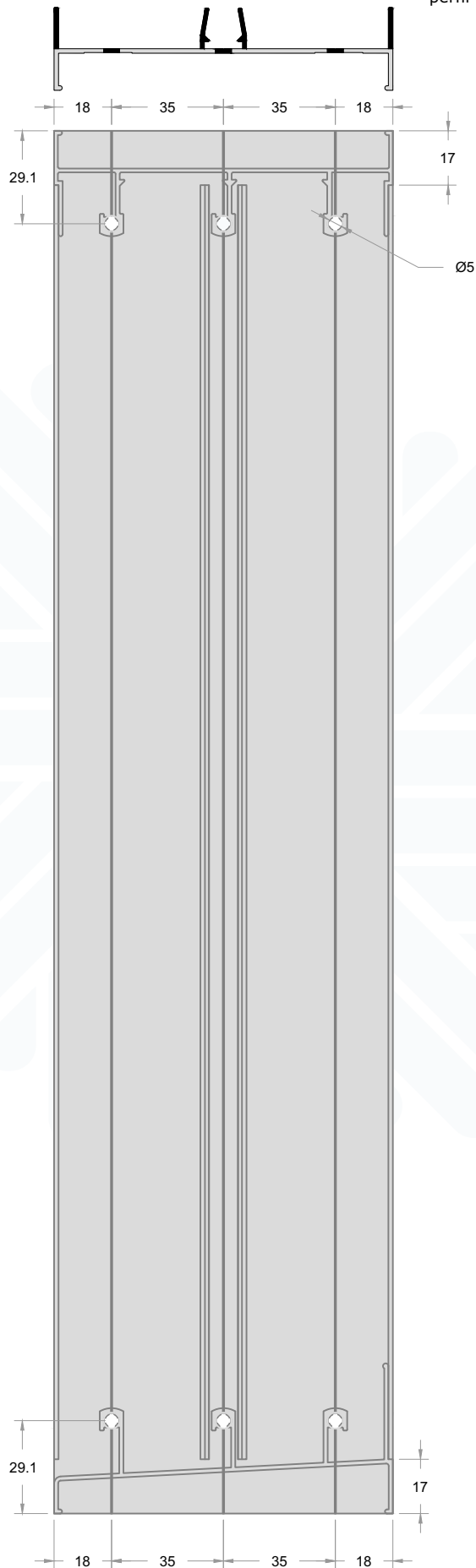

PERFIS
SU-013

Observações:

* Furações dos trilhos inferiores conforme perfil utilizado.

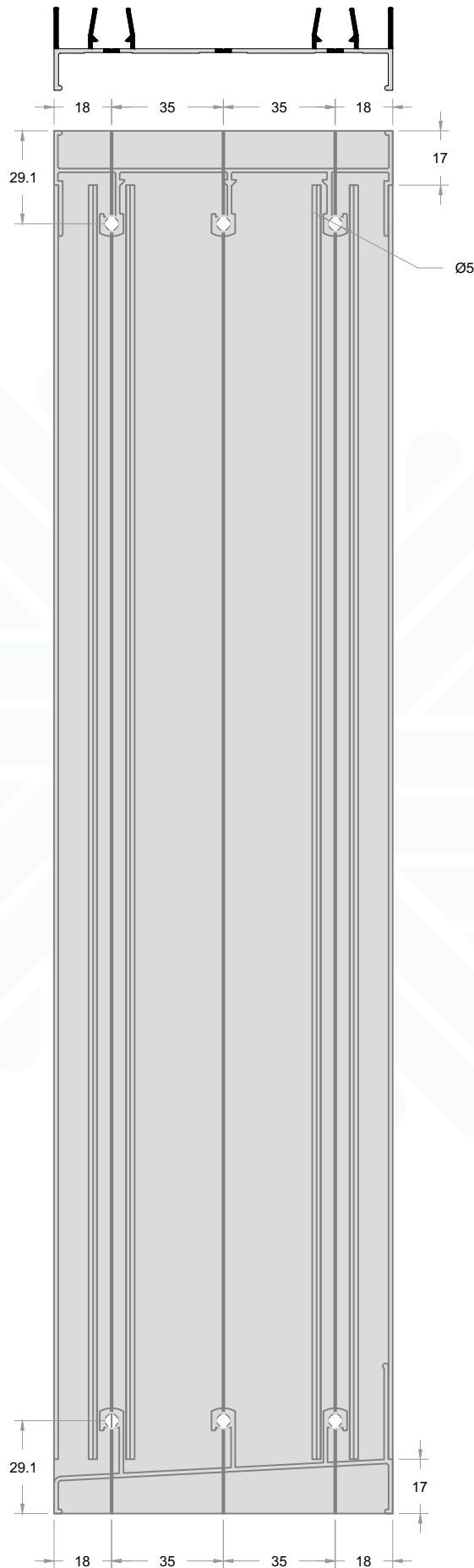

SISTEMA DE ESQUADRIAS LAGUNA 25
REV05

PERFIS
SU-039
SU-280
SU-040
SU-041
SU-044
SU-047
SU-055
SU-056
SU-069
SU-2567
SU-2586
SU-2592
SU-2590
SU-061
SU-057

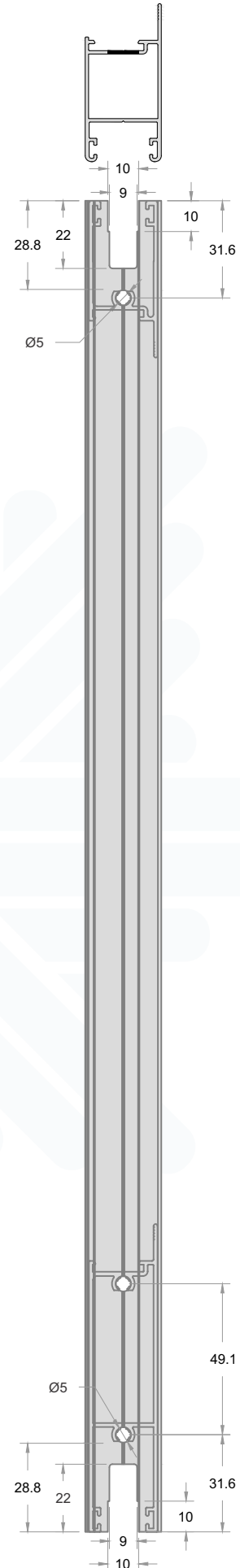

SISTEMA DE ESQUADRIAS  LAGUNA 25
REV05

PERFIS

- SU-280
- SU-044
- SU-047
- SU-2586
- SU-2590
- SU-2592
- SU-061

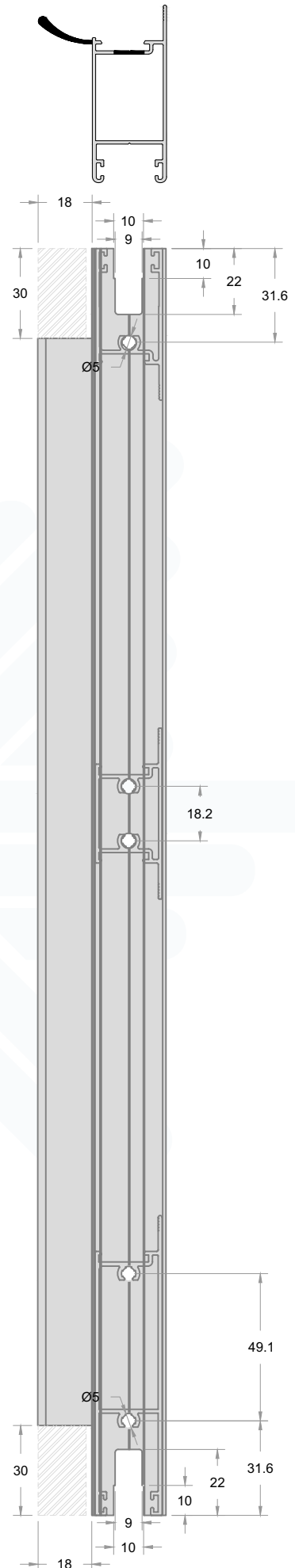
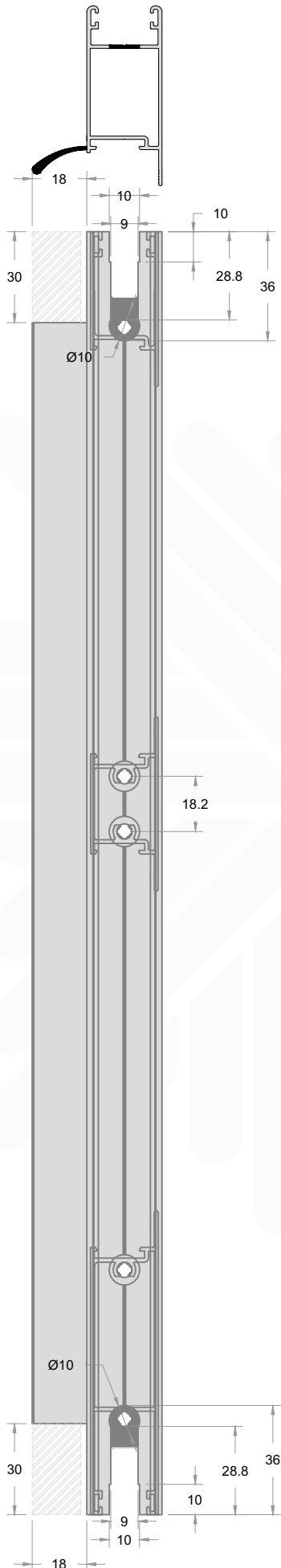

SISTEMA DE ESQUADRIAS LAGUNA 25

REV05

PERFIS
SU-008

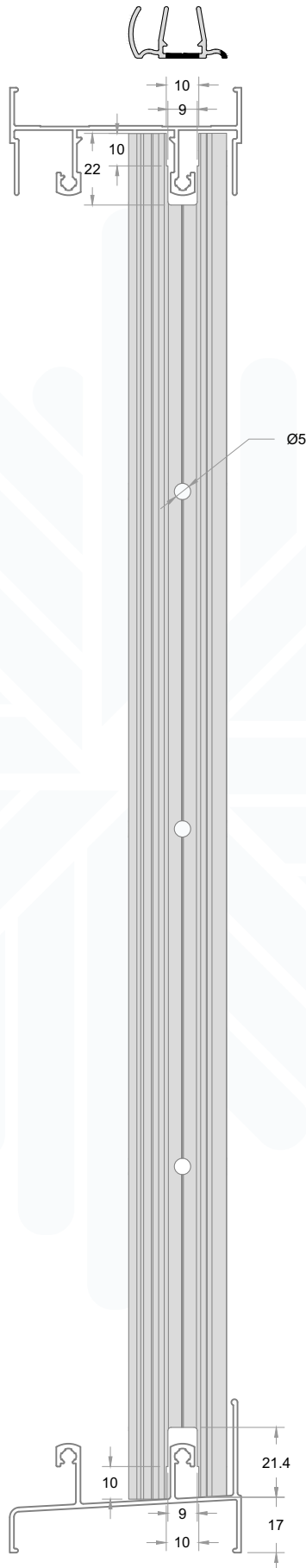

SISTEMA DE ESQUADRIAS  LAGUNA 25

REV05

PERFIS
SU-079

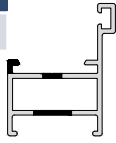

PERFIS
SU-083



PERFIS
SU-086

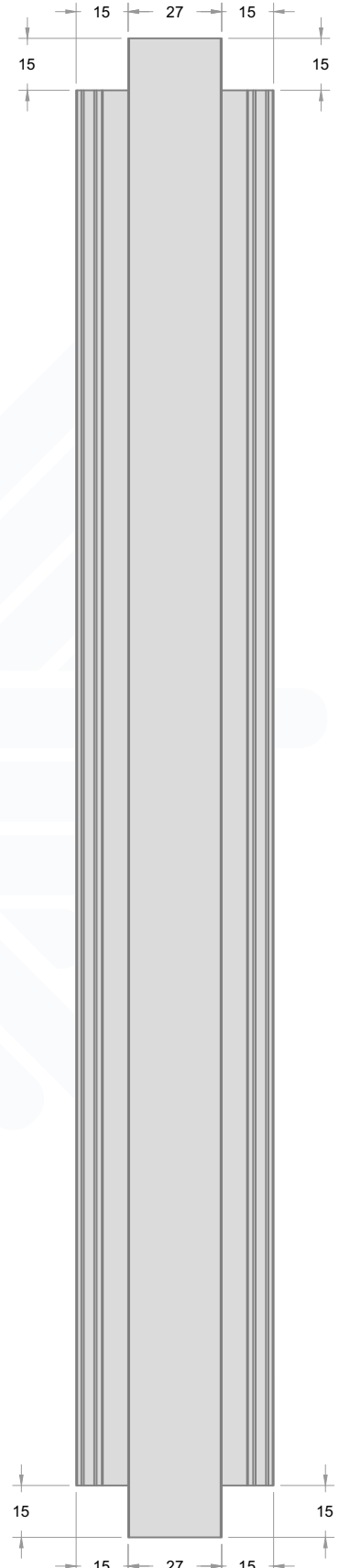
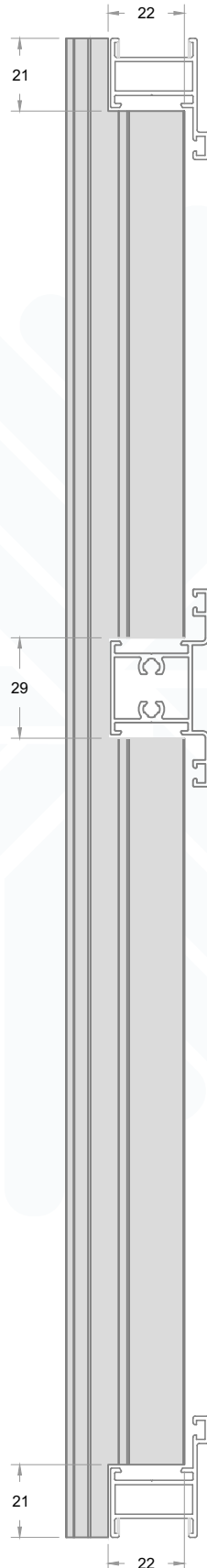
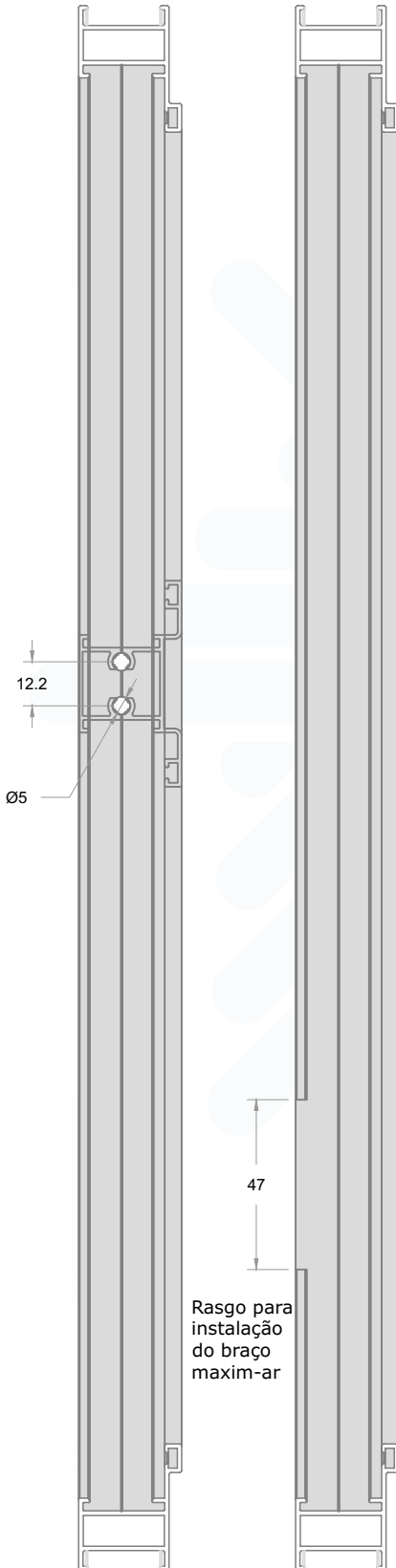
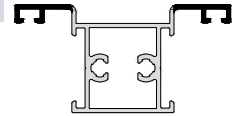

SISTEMA DE ESQUADRIAS LAGUNA 25
REV05

PERFIS
SU-200

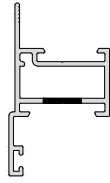
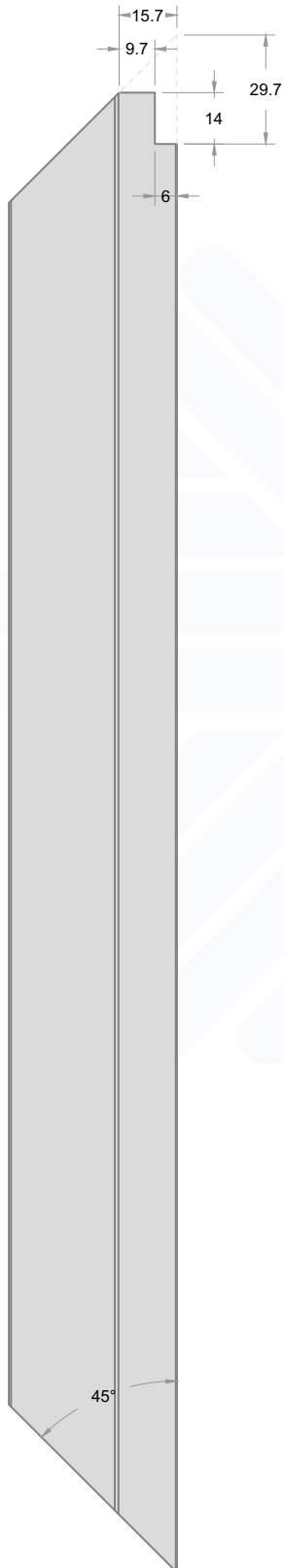
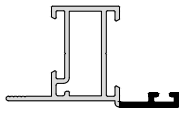

PERFIS
SU-080

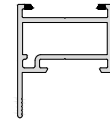

Rasgo para
instalação do
braço maxim-ar

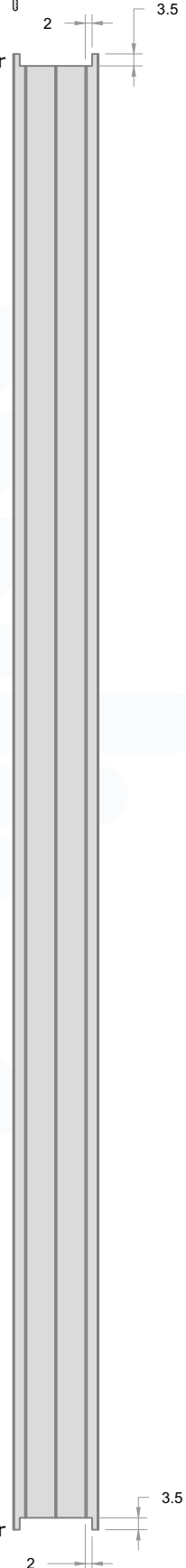
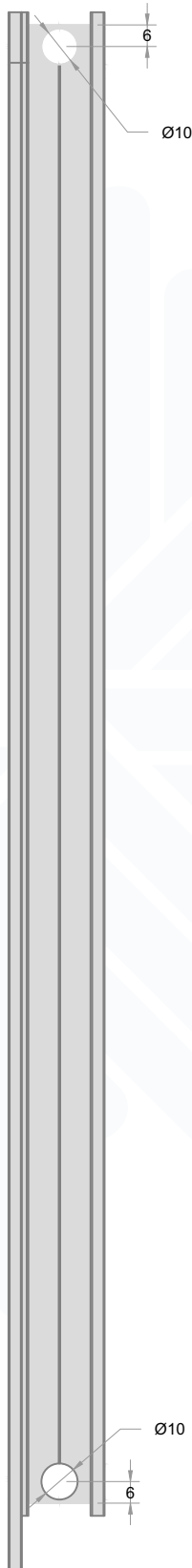

Rasgo para
instalação do
braço maxim-ar

ÍNDICE DETALHES CONSTRUTIVOS

Descrição	Página
JANELA DE CORRER 2 FOLHAS	90
JANELA DE CORRER 2 FOLHAS COM BANDEIRA MAXIM-AR	91
JANELA DE CORRER 3 FOLHAS 2 VENEZIANAS E 1 VIDRO	92
JANELA DE CORRER 4 FOLHAS	94
JANELA DE CORRER 4 FOLHAS COM PEITORIL FIXO	95
JANELA DE CORRER 6 FOLHAS 4 DE VENEZIANAS E 2 VIDRO	93
JANELA MAXIM AR 1 FOLHA	98
JANELA MAXIM AR 2 MÓDULOS COM PEITORIL FIXO	99
PORTA DE CORRER 2 FOLHAS	96
PORTA DE GIRO 1 FOLHA VIDRO E VENEZIANA	100
PORTA DE GIRO 2 FOLHAS	101
PORTA DE CORRER 3 FOLHAS SENDO 2 VENEZIANAS E 1 VIDRO	97

JANELA DE CORRER
2 FOLHAS

- 01 - Todo encontro entre perfis devem ser vedados com silicone neutro.
- 02 - Combinações de Baguetes e EPDM de acordo com tabela na página 69.
- 03- Componentes conforme mapa de Componentes descrito nesse catálogo.

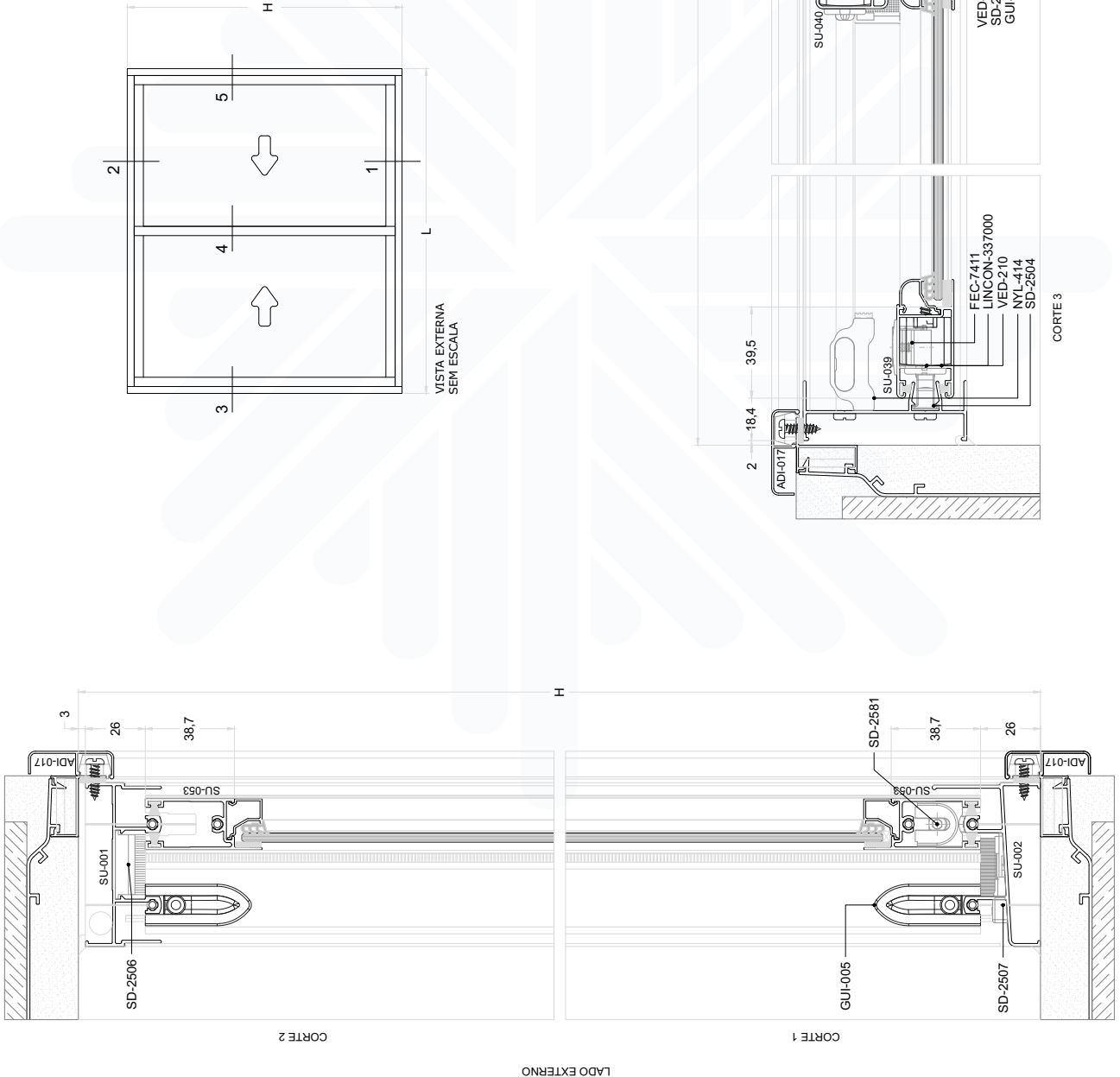

JANELA DE CORRER 2 FOLHAS
COM BANDEIRA MAXIM-AR

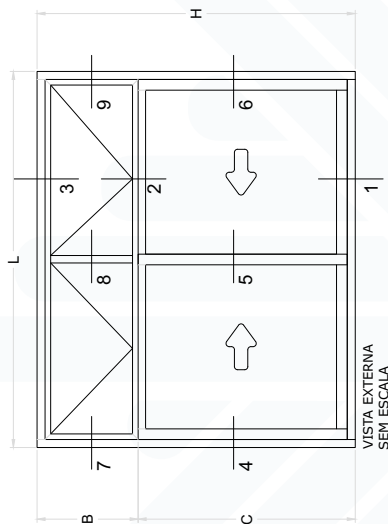

- 01 - Todo encontro entre perfis devem ser vedados com silicone neutro.
- 02 - Combinações de Baguetes e EPDM de acordo com tabela na página 69.
- 03- Componentes conforme mapa de Componentes descrito nesse catálogo.

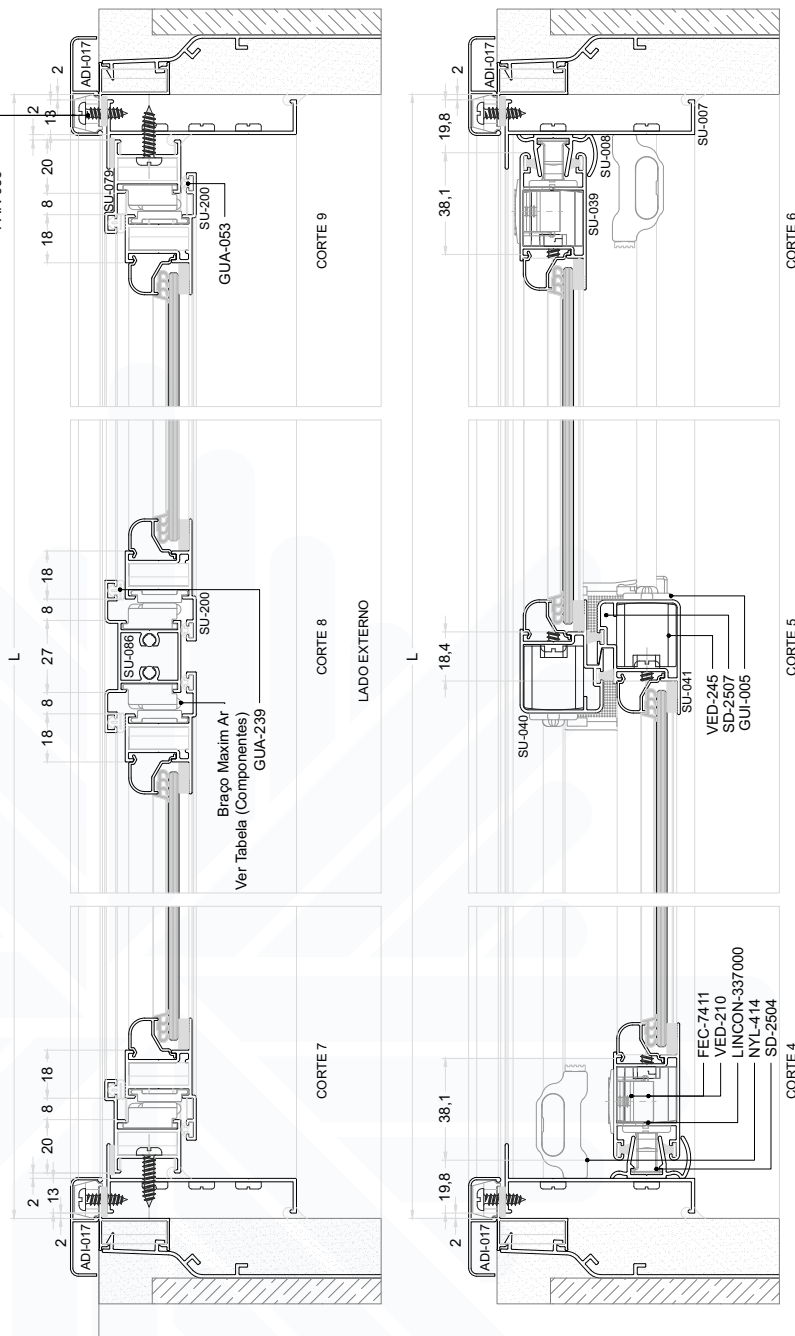
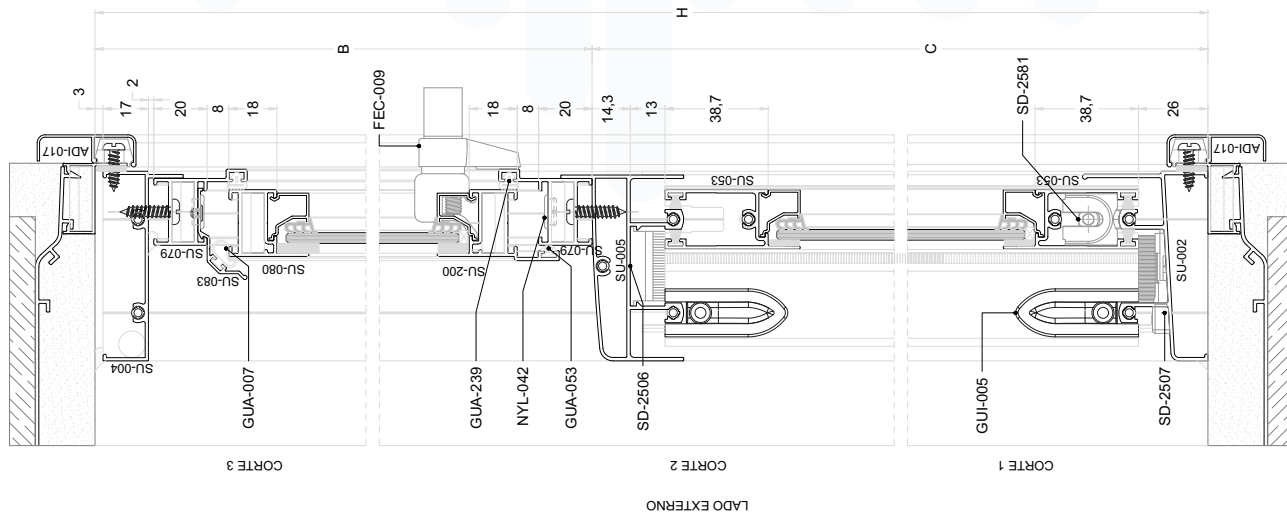

JANELA DE CORRER 3 FOLHAS
2 VENEZIANAS E 1 VIDRO

- 01 - Todo encontro entre perfis devem ser vedados com silicone neutro.
- 02 - Combinações de Bagues e EPDM de acordo com tabela na página 69.
- 03- Componentes conforme mapa de Componentes descrito nesse catálogo.

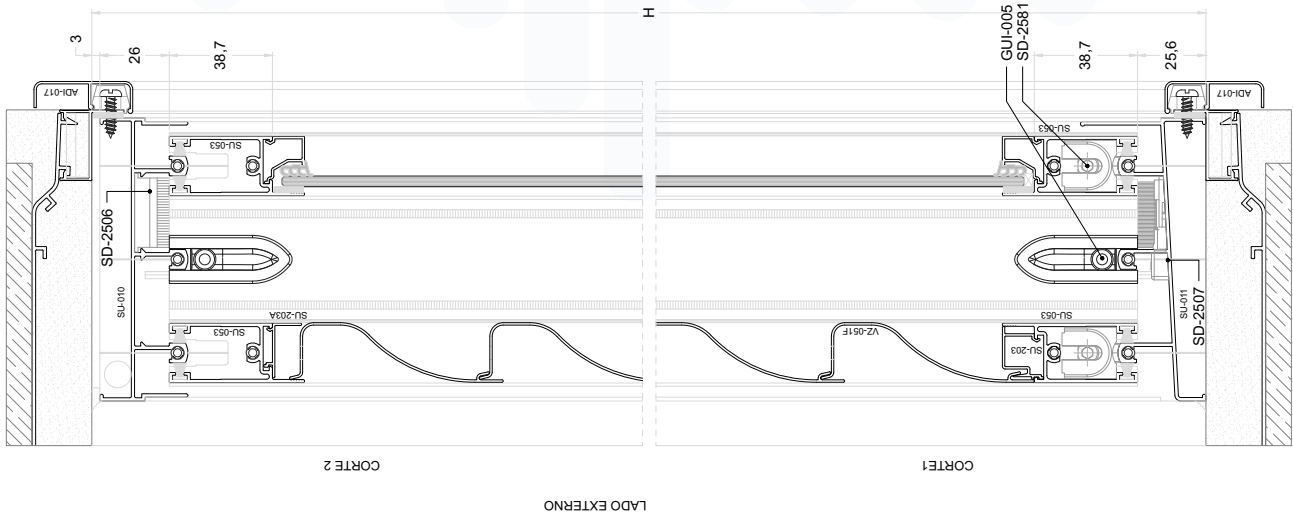
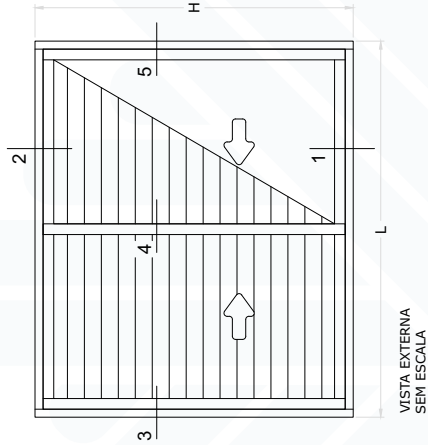

JANELA DE CORRER 4 FOLHAS
COM PEITORIL FIXO

- 01 - Todo encontro entre perfis devem ser vedados com silicone neutro.
- 02 - Combinações de Baguesetes e EPDM de acordo com tabela na página 69.
- 03 - Componentes conforme mapa de Componentes descrito nesse catálogo.

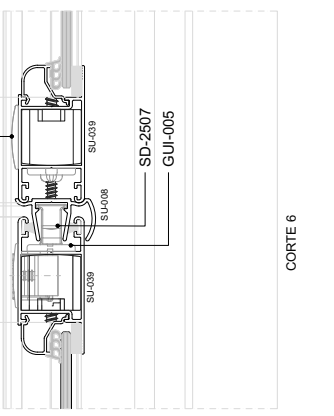
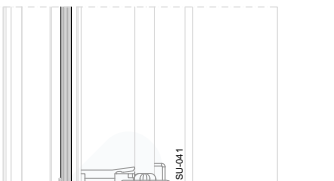
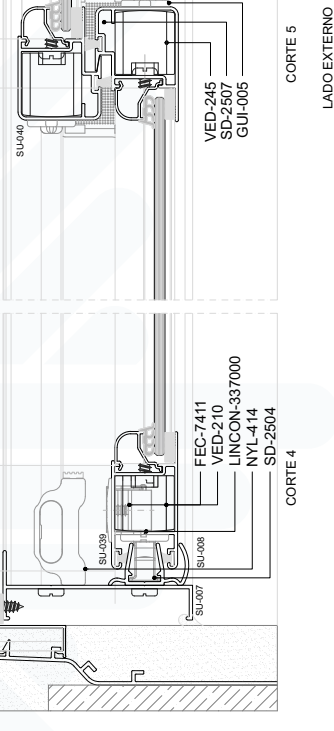
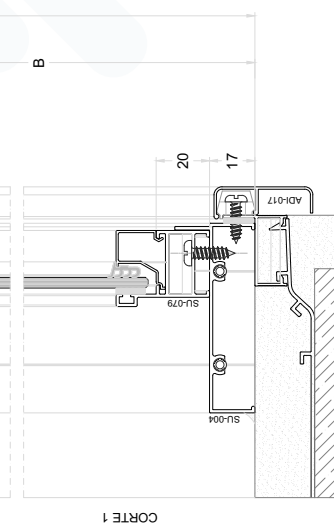
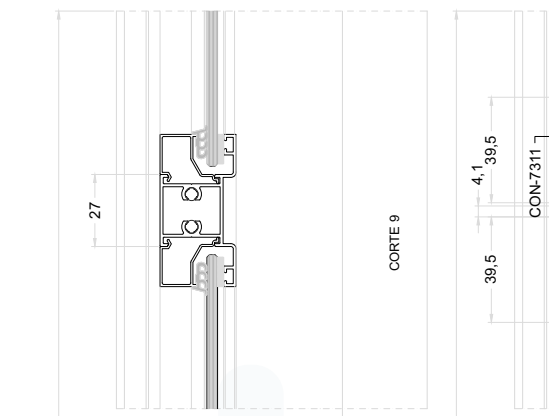
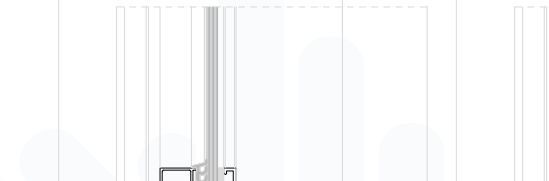
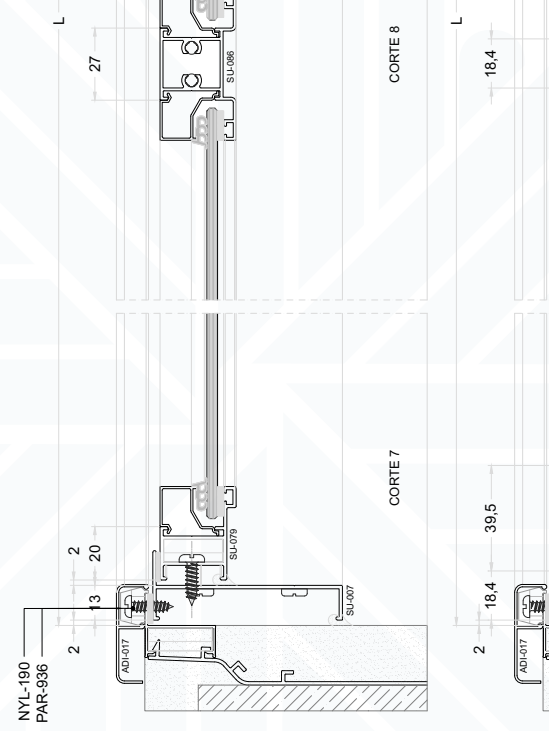
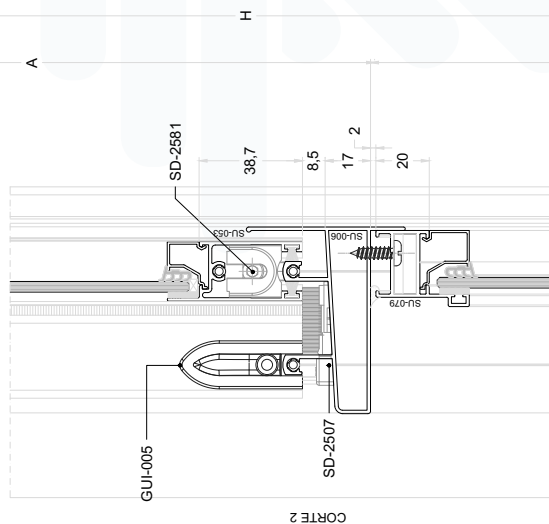
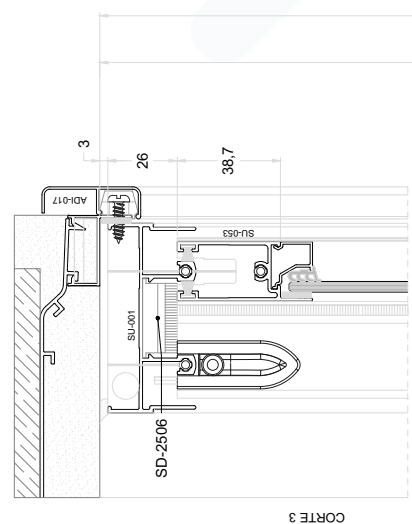
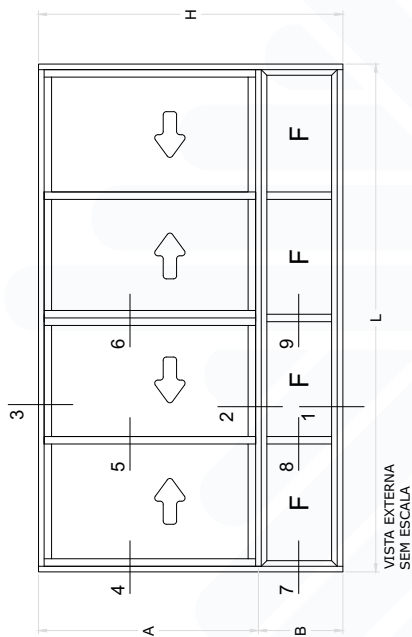

LADO EXTERNO

**PORTA DE CORRER
2 FOLHAS**

- 01 - Todo encontro entre perfis devem ser vedados com silicone neutro.
- 02 - Combinações de Baguetes e EPDM de acordo com tabela na página 69.
- 03- Componentes conforme mapa de Componentes descrito nesse catálogo.

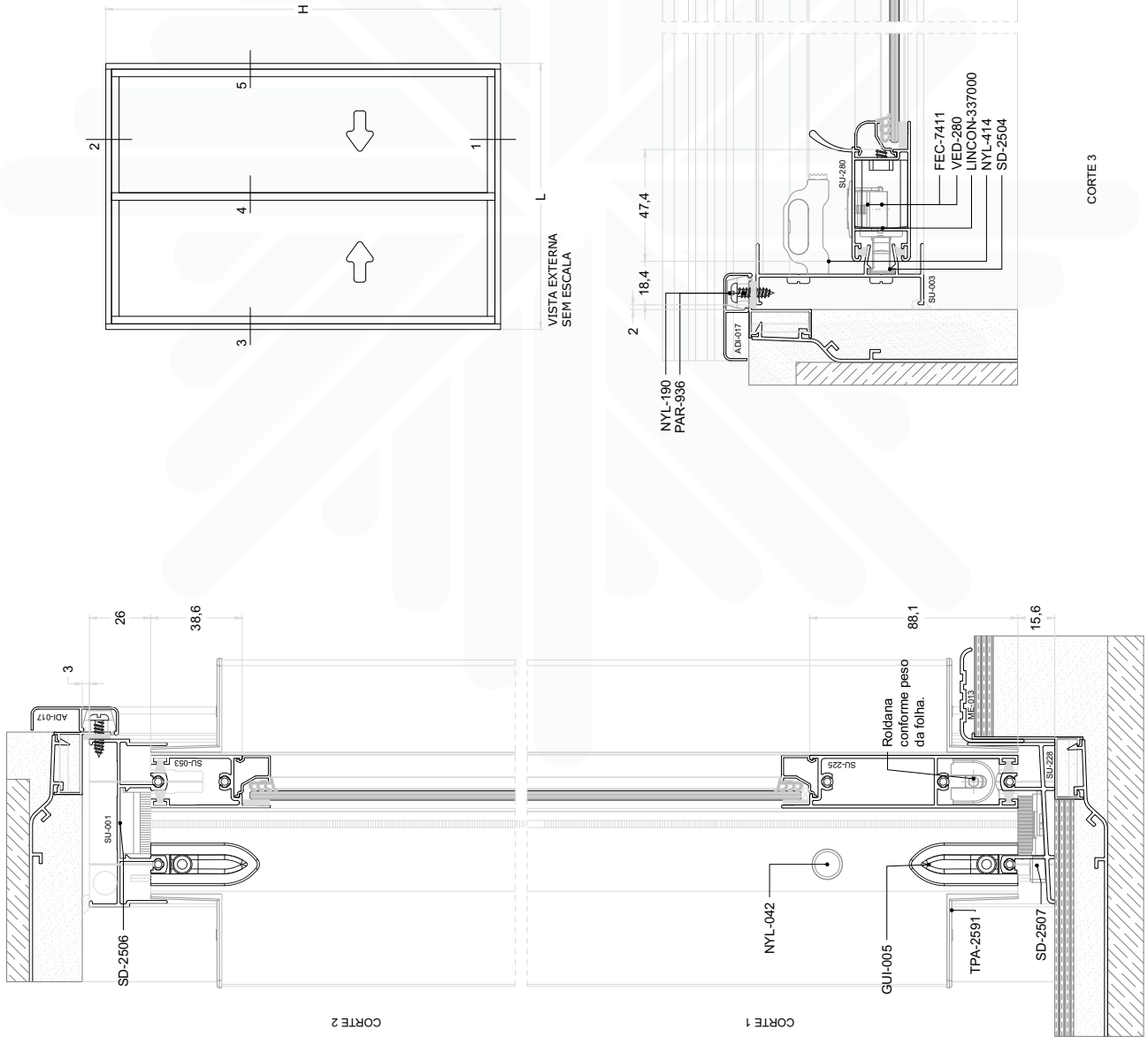

PORTA DE CORRER 3 FOLHAS
SENDO 2 VENEZIANAS E 1 VIDRO

- 01 - Todo encontro entre perfis devem ser vedados com silicone neutro.
- 02 - Combinações de Baguetes e EPDM de acordo com tabela na página 69.
- 03 - Componentes conforme mapa de Componentes descrito nesse catálogo.

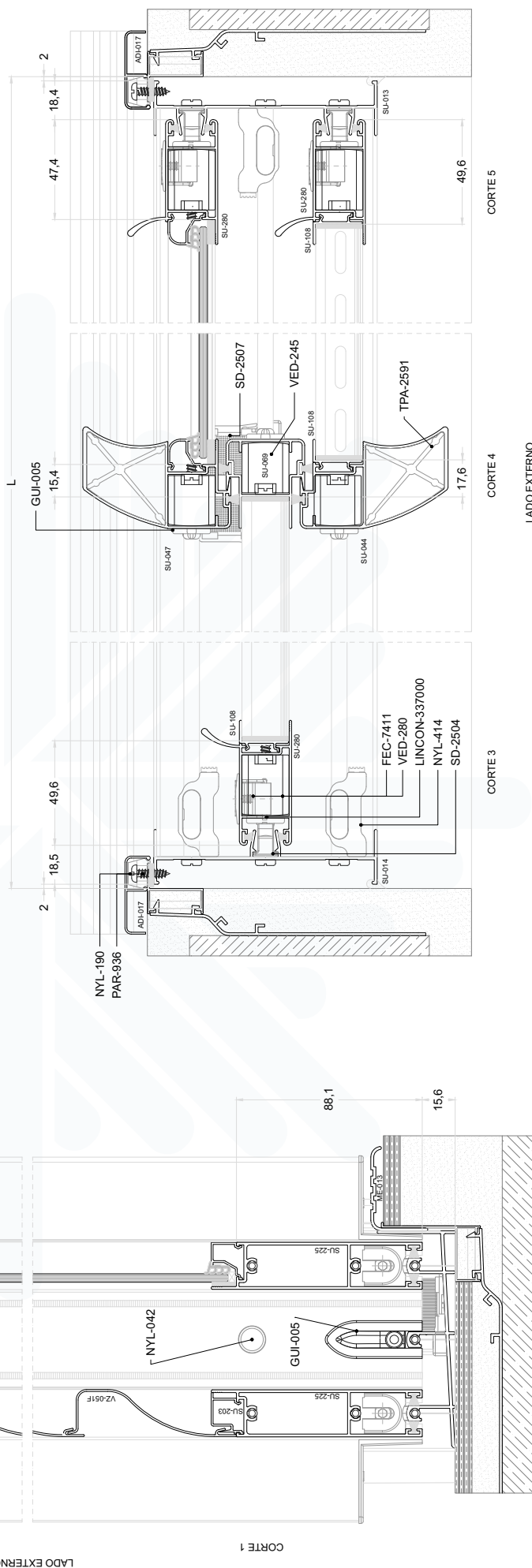
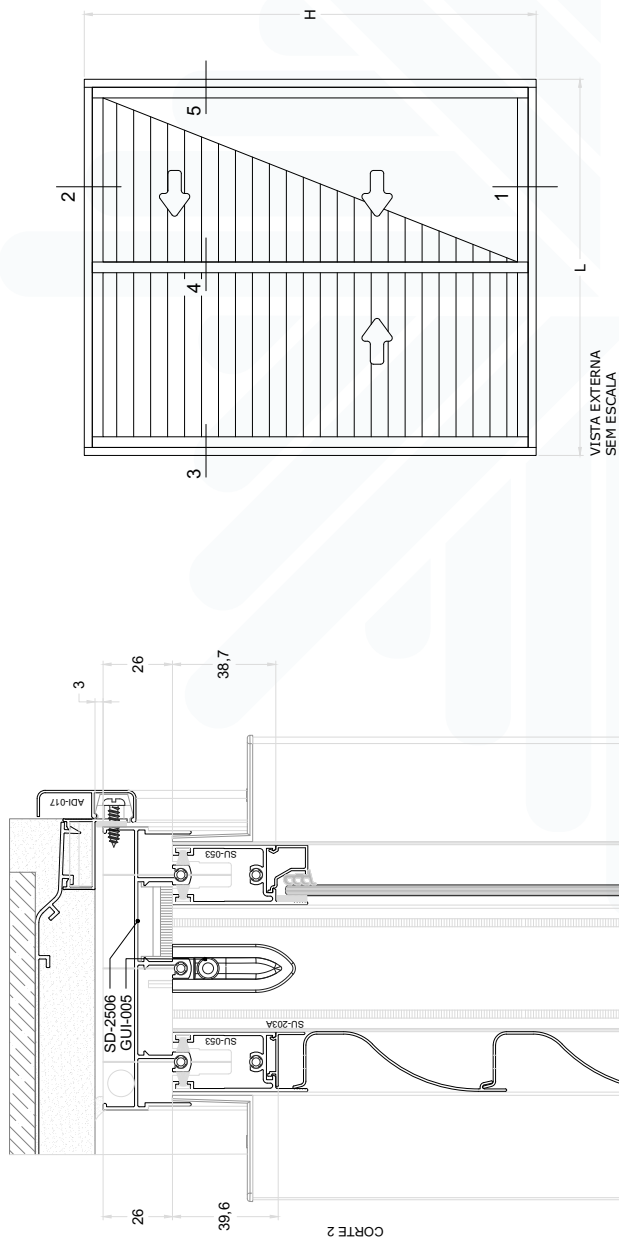

JANELA MAXIM AR
1 FOLHA

- 01 - Todo encontro entre perfis devem ser vedados com silicone neutro.
- 02 - Combinações de Bagues e EPDM de acordo com tabela na página 69.
- 03- Componentes conforme mapa de Componentes descrito nesse catálogo.

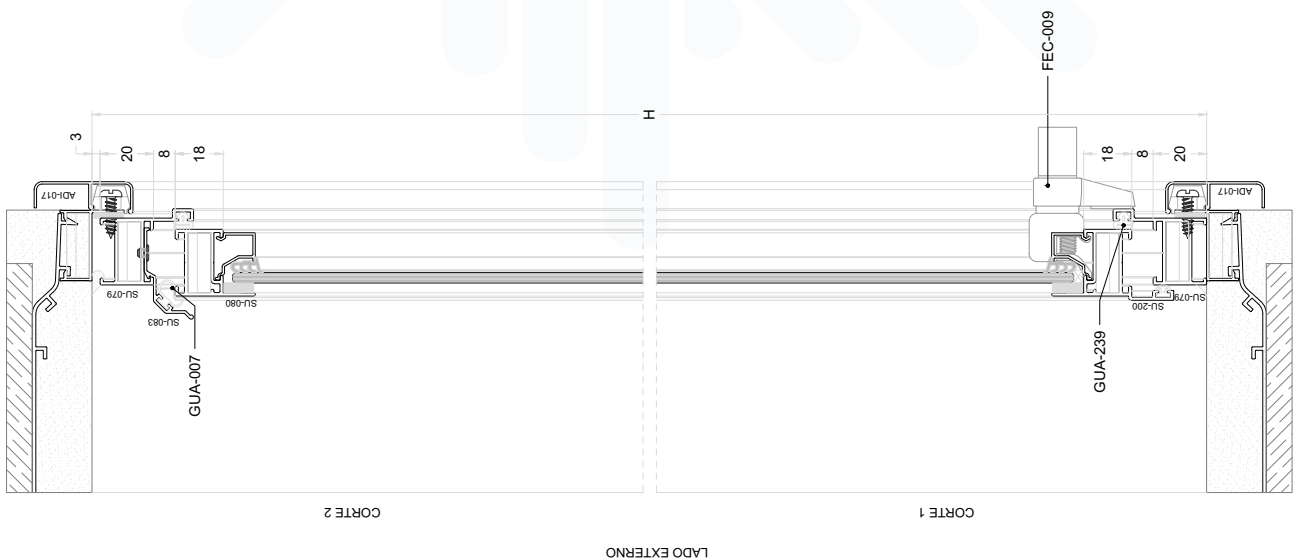
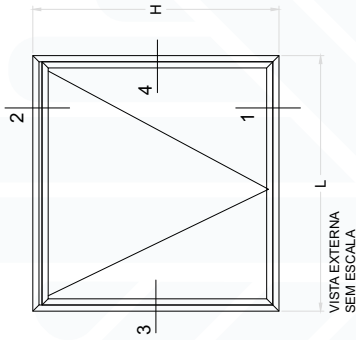

**PORTA DE GIRO 1 FOLHA
VIDRO E VENEZIANA**

- 01 - Todo encontro entre perfis devem ser vedados com silicone neutro.
- 02 - Combinações de Baguetes e EPDM de acordo com tabela na página 69.
- 03- Componentes conforme mapa de Componentes descrito nesse catálogo.

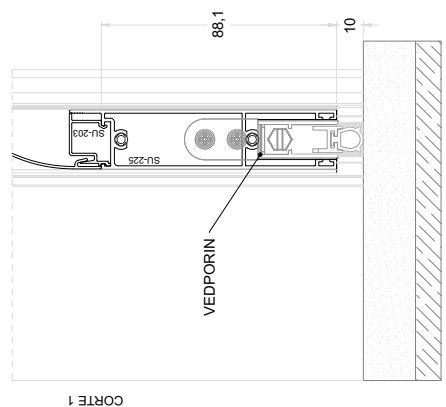
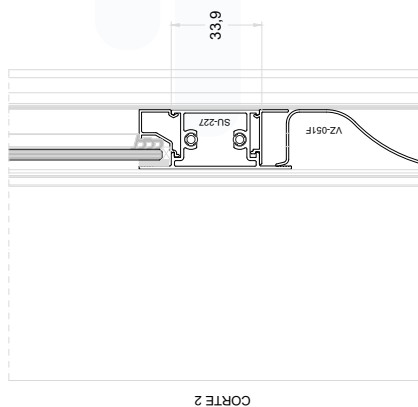
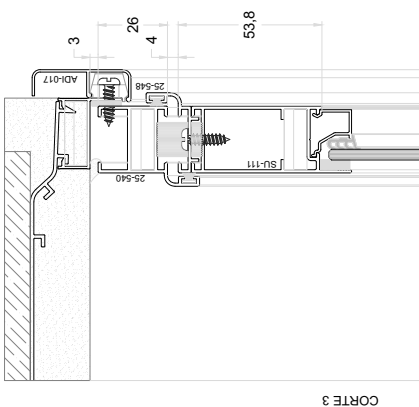
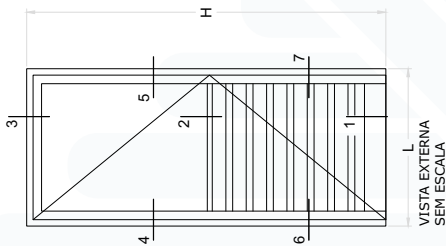

LADO EXTERNO

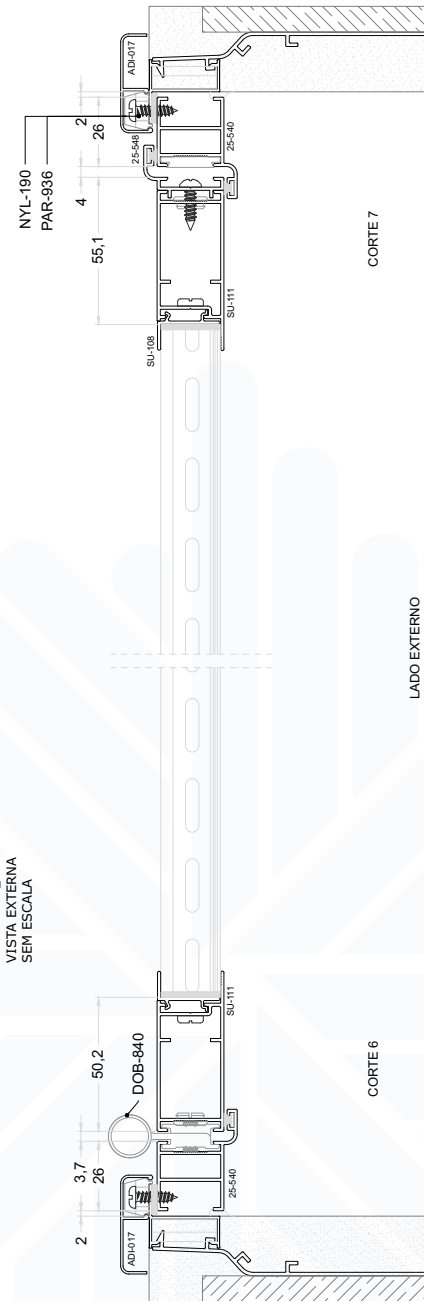

LADO EXTERNO

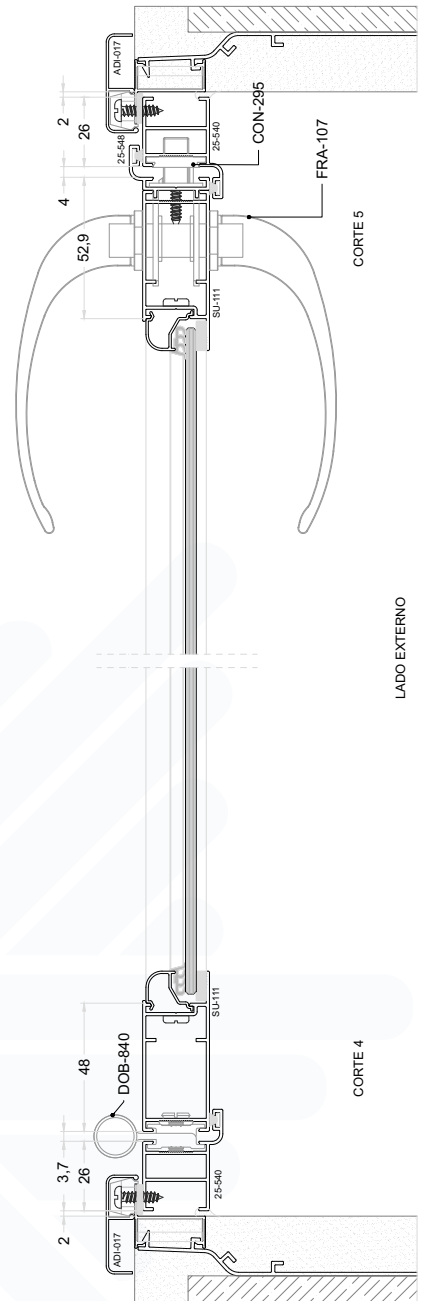

LADO EXTERNO

PORTA DE GIRO
2 FOLHAS

- 01 - Todo encontro entre perfis devem ser vedados com silicone neutro.
- 02 - Combinações de Baguetes e EPDM de acordo com tabela na página 69.
- 03- Componentes conforme mapa de Componentes descrito nesse catálogo.

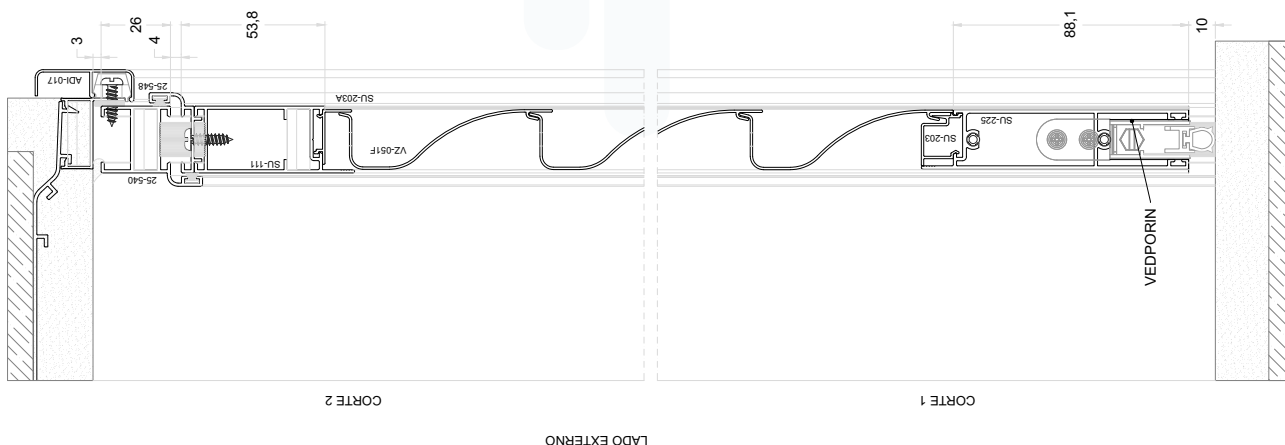

LADO EXTERNO

LADO EXTERNO



Administração

Av. Marechal Deodoro, 335 - 3º andar
Tubarão - SC - 88701-010

Indústria

Rodovia SC 390, Km 10
Termas da Guarda - Margem Direita
Tubarão - SC - 88702-803